



3/2	Product overview
3/3	Introduction
3/18	Compact ranges I to III
3/20	- Compact range III
3/22	- Compact range II
3/23	- Compact range I
3/24	- Configuration aids
3/26	M18 compact range
3/28	M18 S compact range
3/30	Compact range for pump control
3/31	K08 compact form
3/32	Compact range 0
3/34	3SG16 compact form
3/36	K65 compact form
3/39	Thru-beam sensor
3/41	Double-layer sheet monitoring
	Accessories
3/43	SONPROG PC interface
3/45	Mounting accessories



Product overview

Overview

The following table lists the most important technical features of the individual ranges.

	Compact range I	Compact range II	Compact range III	Compact range M18	Compact range M18 S	Compact form K08	Compact range 0	Compact form 3SG16	Compact form K65	Sonar thru-beam sensor	Double-layer sheet monitoring
Operating mode											
Diffuse sensor	■	■	■	■	■	■	■	■	■		
Reflex sensor	■	■	■	●	■	■		■	■		
Thru-beam sensor		■	■	■		■				■	■
Output											
1 switching output	■	■		■	■		■		■	■	
2 switching outputs		■				■		■	■		■
1 switching output + 1 analog output			■								
1 analog output				■			■		■		
1 frequency output		■		■	■				■		
Analog output											
0 to 20 mA			■	■					■		
4 to 20 mA			■	■					■		
0 to 10 V			■	■			■		■		
Adjustment											
1 potentiometer				■			■				
2 potentiometers	■	■	■	■					■		
SONPROG PC interface		■	■	■					■		
Plug-in jumpers								■			
Teach-in		■	■		■	■			■		■
Keys										■	
Wiring										■	
Parameters adjustable using SONPROG											
Blind zone		■	■	■					■		
End of sensing range		■	■	■					■		
Lower limit of operating range		■	■	●					■		
Upper limit of operating range		■	■	●					■		
Differential travel		■	■	●					■		
NO/NC function		■	■	●					■		
Lower limit of analog range			■	●							
Upper limit of analog range			■	●							
Characteristic of analog output			■	●							
Current range of analog output			■	●							
Mean value generation		■	■	■					■		
Function mode		■	■	■							
Temperature compensation		■	■	■					■		
Enabling/disabling of potentiometers		■	■	●							
For description, see page	3/18	3/18	3/18	3/26	3/28	3/31	3/32	3/34	3/36	3/39	3/41
For selection and ordering data, see page	3/23	3/22	3/20	3/27	3/29	3/31	3/33	3/35	3/37	3/40	3/42

■ Sonar-BERO programmable using SONPROG interface device

- Available
- Only available for units with switching output
- Only available for units with analog output

Overview



Sonar-BEROs can be used as non-contact proximity switches in many fields of automation. Whenever distances through air have to be evaluated, these devices can be used, because they not only detect objects, but can also output and evaluate the absolute distance between the Sonar-BERO and the object. Changing environmental conditions (e. g. temperature variations) are compensated during evaluation of the measurement.

Sonar-BEROs measure the runtime of the ultrasonic pulse emitted by the BERO and reflected by the object from which they can calculate the distance to the object. Sonar-BEROs can operate over extremely short (6 cm) or extremely long distances (10 m) with ease.

With the SONPROG software, it is easy to calibrate the BERO to the object and operating range (e.g. minimum fill level).

Area of application

The wide range of areas of application for the Sonar-BERO ultrasonic sensors gives full rein to the imagination:

- Fill level and height sensing
- Spacing measurement
- Winding diameter sensing
- Bottle counting, and much more.

The Sonar-BEROs are extremely rugged and insensitive to dirt, vibration and ambient noise.

Objects

Using ultrasonic technology, Sonar-BEROs can detect objects of any kind, this includes liquids, powders or granulates, and colored or transparent objects. Whether the surface of the object is rough or smooth, clean or dirty, wet or dry is of no consequence.

Even at a maximum operating distance, all level or smooth surfaces can be reliably detected up to an angular variation of approximately 3° from the sound cone. Depending on the peak-to-valley height of the object, the angular variation may also be higher.

As a rule, the objects can enter the sound cone from any direction.

Explosion protection

The Sonar-BEROs of compact ranges 0 to III and M18 as well as the sonar thru-beam sensors and compact form sensors 3SG 16 and K65 are suitable for installation in Ex-Zone 2 and Ex-Zone 11.

Personal safety



Due to their physical characteristics, the Sonar-BERO ultrasonic proximity switches cannot be used for safety-related applications (e.g. for the protection of personnel).

Application examples

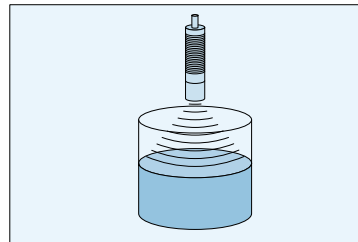

Level measurement in large tanks:
K65 compact form with minimum/maximum monitoring (up to 2.5 m),
M18 compact range with analog output (up to 1 m),
compact range III (up to 6 m)

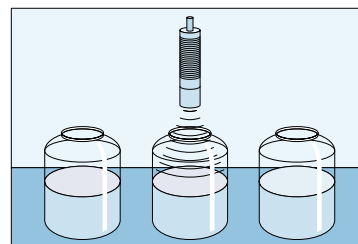

Level measurement in small bottles:
M18 compact range with analog output

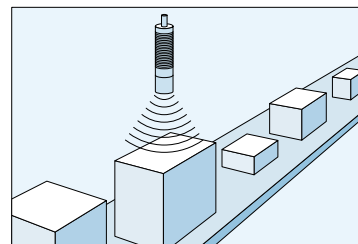

Size measurement:
M18 compact range with analog output (up to 1 m),
compact range III (up to 6 m)

Sonar-BERO

Introduction

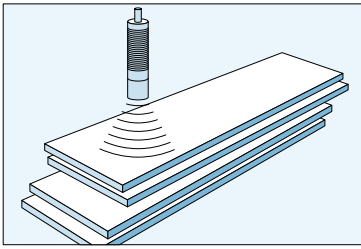

Measurement of stack height:
M18 compact range with analog output (up to 1 m),
compact range III (up to 6 m)

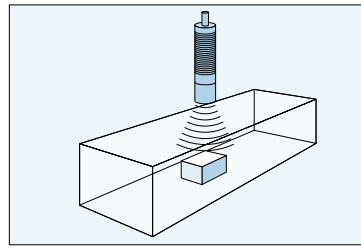

Object measurement:
M18 compact range with switching output

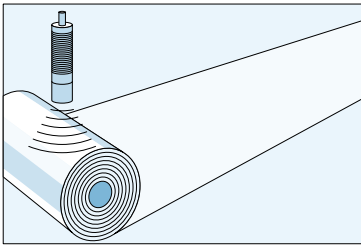

Measurement of diameter and speed:
M18 compact range with analog output (up to 1 m),
compact range III (up to 6 m)

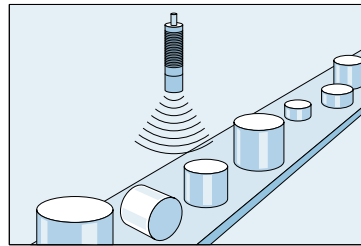

Quality inspection:
M18 compact range with switching output,
compact range II (up to 6 m)

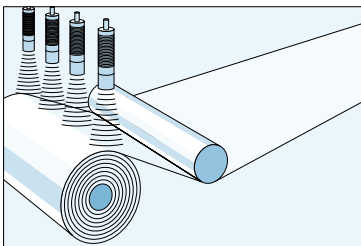

Contour measurement (synchronization):
M18 compact range with analog output (up to 1 m),
compact range III (up to 6 m)

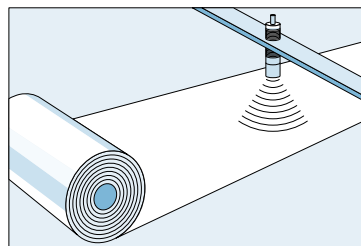

Breakage monitoring:
M18 compact range with switching output (up to 30 cm)

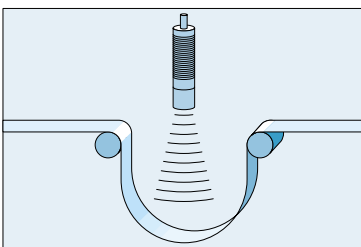

Loop monitoring:
K65 compact form with minimum/maximum monitoring (up to 2.5 m),
compact range II with 2 switching outputs

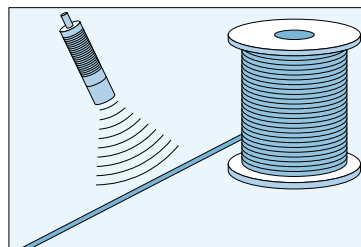

Wire and rope breakage monitoring:
M18 compact range with switching output,
compact range II

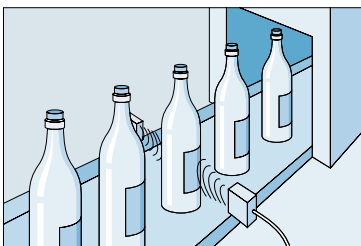

Bottle counting and detection of intervals:
Sonar thru-beam sensor

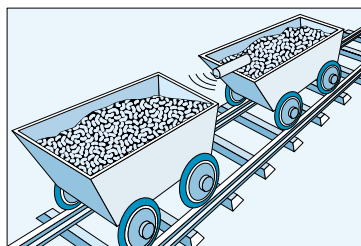

Distance monitoring:
compact range II with 2 switching outputs (up to 6 m)

Special applications

	Compact range 0, I, II, III, M18 (special version)	Compact range 0, I, II, III, M18 (special version)	Compact range II with 2 switching outputs (special version)	Compact range II, M18 (special version)	Compact form K65	Compact range II with 2 switching outputs (special version)	Compact range II with frequency output	Compact range II (special version)	Sonar thru-beam sensor	Compact range II (special version)
In chemically corrosive medium Ultrasonic transducer with Teflon foil	■									
For food processing Ultrasonic transducer with Teflon foil, PPS ring, enclosure made of stainless steel V4A		■								
Stroke control for machines with minimum/maximum detection 2 separately adjustable switching points			■							
Level monitoring for pump control with 1 switching output Switching point for "Full" signal and pump stroke separately adjustable				■						
Level monitoring for pump control with 2 switching outputs For "Full" message with differential travel 1, for limit switch-off with differential travel 2, level-dependent averaging					■					
Roll diameter monitoring Prewarning with switching output 1, limit switch-off with switching output 2						■				
Threshold measurement using LOGO! The frequency output is measured by the counter inputs of the LOGO! control units: several threshold values assigned to the relay outputs of the LOGO! control unit							■			
Gate control, entrance control Parameterizable pick-up/drop-out delay, Sonar-BERO used for operating gates								■		
Transport belt control Used in cabinet with emitter and receiver: no blind zone, max. switching frequency 200 Hz, insensitive to dust and condensation									■	
Loop control for control of sag Averaging and differential travel with echo pulse detection										■
For description, see page				3/30	3/36		3/22		3/39	

Introduction

Design

Mounting

Sonar-BEROs can be operated in any mounting position. Mounting positions in which deposits can settle on the transducer surface must however be avoided.

The best results are obtained if the Sonar-BEROs are aligned such that the ultrasound waves hit the object as near to the vertical as possible. If this is not possible (e.g. in the case of bulk material), the maximum possible range must be determined experimentally. This depends on the material, surface and alignment of the objects.

To prevent undesirable reflections, the distance *a* must be maintained from disturbing objects around the axis of the sound cone.

Between the sound cone axis and a smooth wall running in parallel to it, the distance *b* must be maintained to prevent disturbing reflections. The distance *c* must be maintained to ensure that no objects enter the blind zone (see sound cones).

Mounting multiple sensors

Mutual interference between Sonar-BEROs that can result in spurious signals is excluded by maintaining sufficient distances between the sensors or an appropriate alignment.

If two Sonar-BEROs of an identical design are mounted opposite each other, the distance *d* must be maintained between them. If two sensors of identical design are arranged in parallel, the distance *e* must be maintained between the sensors.

To avoid mutual interference, BERO sensors of compact ranges 0, II, III and M18 can be synchronized or operated in multiplex mode (see Functions).

Fouling

The range of the BERO is reduced if the transducer surface is damaged or painted or if water or wet dirt is applied to it.

Clearance *a* around the axis of the sound cone: keep space free of objects

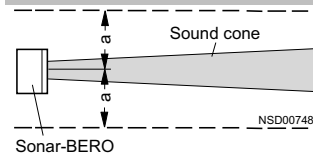

Sonar-BERO with sensing range	A
cm	cm
6 (5) ... 30	> 6
20 ... 130 (100)	> 30
40 ... 300	> 60
60 ... 600	> 90
80 ... 1000	> 150

Distance *b* between two Sonar-BEROs and a smooth surface

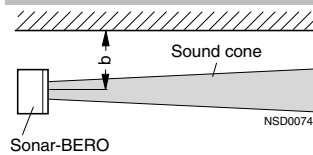

Sonar-BERO with sensing range	s
cm	cm
6 (5) ... 30	> 3
20 ... 130 (100)	> 15
40 ... 300	> 30
60 ... 600	> 40
80 ... 1000	> 70

Distance *d* between two Sonar-BEROs mounted opposite each other with the same sensing range

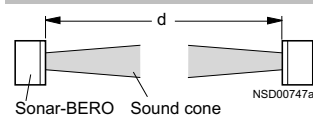

Sonar-BERO with sensing range	d
cm	cm
6 (5) ... 30	> 120
20 ... 130 (100)	> 400
40 ... 300	> 1200
60 ... 600	> 2500
80 ... 1000	> 4000

Distance *e* between two Sonar-BEROs arranged in parallel with the same sensing range, object perpendicular to the axis of the sound cone

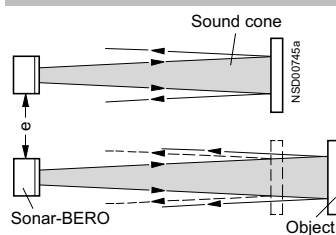

Sonar-BERO with sensing range	e
cm	cm
6 (5) ... 30	> 15
20 ... 130 (100)	> 60
40 ... 300	> 150
60 ... 600	> 250
80 ... 1000	> 350

Distance *e* between two Sonar-BEROs arranged in parallel with the same sensing range, object with unfavorable orientation

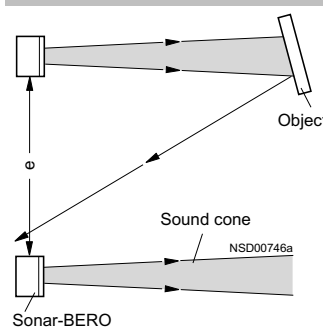

The distance *e* must be experimentally determined depending on the angle between the object and the Sonar-BERO.

Functions

The Sonar-BEROs only operate through the medium of air and can detect any object that reflects ultrasound.

The sensors emit ultrasonic pulses cyclically. When an object reflects these pulses, the generated echo is received and converted into an electrical signal. The incoming echo is detected in accordance with its intensity which, in turn, is dependent on the distance between the object and the Sonar-BERO.

The Sonar-BEROs operate according to the echo propagation principle i.e. the time difference between the emitted pulse and the echo pulse is evaluated.

The construction of the sensor causes the ultrasonic beam to be emitted in the shape of a cone. Reflecting objects are only detected within this sound cone. Within the blind zone, which lies between the sensor surface and the sensing range, echoes cannot be evaluated for physical reasons.

Resolution

The resolution is the smallest change in the distance to the object that is necessary for a change in the output of the BERO. The internal resolution is 256 or 4096 steps. If values are entered during programming that exceed this resolution, the program will automatically correct them. The corrected values will be displayed in a window with a message.

Example

Sonar-BERO 3RG6014-..... (60 to 600 cm)

For a sensing range 60 to 600 cm, this results in a resolution of 1.3 mm:

$$6000 \text{ mm} \text{ minus } 600 \text{ mm} = 5400 \text{ mm}$$

$$5400 \text{ mm}/4096 = 1.3 \text{ mm (12 bit)}$$

If the measuring range is restricted, the step size is reduced because the distance that is split up into 4096 steps has reduced. The smallest step size is, however, limited to 1 mm by the electronics. If the sensing range is restricted, the resolution is enhanced.

Temperature compensation

The Sonar-BEROs of compact range II, III and M18 as well as modular range II are fitted with temperature sensors and a compensation circuit that equalizes changes in operating distances caused by temperature changes.

Compensation can be performed throughout the temperature range. This means that an absolute precision of +/- 1.5 % (compact ranges II and III) or of +/- 2.5 % (compact range M18) is achieved.

Operating modes with switching output

The Sonar-BEROs with switching output (the graphics describe sensors with NO function) can be used in the following modes depending on their type.

Only emitter, only receiver

Two Sonar-BEROs are required in each case for this operating mode. One is parameterized as a receiver and the other is parameterized as the emitter. There are two possible applications:

Thru-beam sensor:

It is only evaluated whether an object lies between the BEROs. The range is twice the normal range. Adjustment of the operating range and evaluation of the analog output is not relevant in this case.

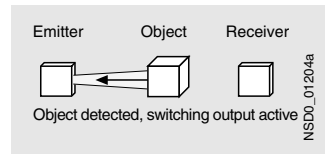

Active measurement system:

The propagation time of the ultrasonic signal from the emitter to the receiver is measured. The enabling inputs of the two BEROs must be connected together for this purpose. All options of the BEROs can still be used; the range is twice the normal range.

Emitter and receiver

This is the normal operating mode of the Sonar-BERO; it operates as a typical proximity switch.

Diffuse sensor:

In this case, the object that is to be detected acts as a reflector. As soon as an object enters the preset operating range, the echo from this object causes the output signal of the BERO to change.

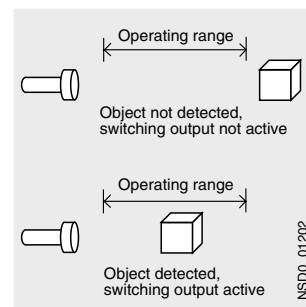

Reflex sensor:

In this case, a permanently fixed reflector (e.g. a small metal plate) is mounted opposite the BERO. The operating range is adjusted to this reflector. If the path between the BERO and the reflector is interrupted, the sensor no longer detects the reflector and this triggers a change in the signal at the switching output.

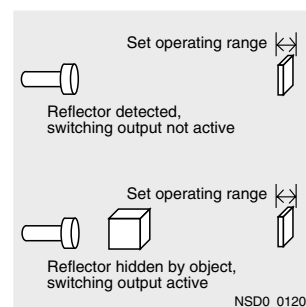

Synchronization

In compact ranges 0, II, III and M18, several devices can be synchronized with each other by simply interconnecting the synchronization outputs of the devices (Pin 2 for NO function, Pin 4 for NC function). Up to 10 devices can be synchronized (or 6 devices in the case of compact range 0). This allows the sensors to be mounted extremely close to each other in many cases without causing mutual interference.

Advantages:

- No additional wiring overheads, simply connect the enable inputs of the individual BEROs.
- Fast response, because every BERO is constantly active.

Disadvantages

- The object cannot be assigned to a particular BERO.

Sonar-BERO

Introduction

Example

Two Sonar-BEROs are mounted at a clearance e that is smaller than the minimum clearance (see mounting guidelines). An object is located in their common sound field. The echo from B2 can reach B1 by reflection (GB). Mutual interference can occur. The object is detected from the two echoes E1 and E2 by Sonar-BEROs B1 and B2. If the two devices are synchronized, there may be no mutual interference, because for example, echo E1 arrives after echo E2 at BERO B2. The devices only ever respond to the first echo.

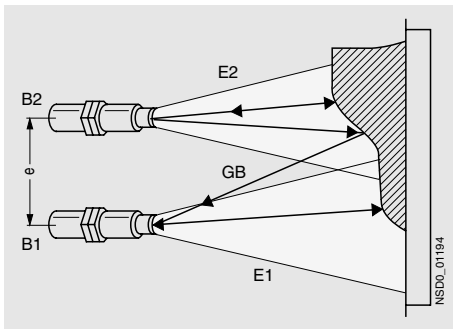

Multiplex function

External multiplex mode

The fourth connection can be used as an external enabling input. This can be used to switch the Sonar-BERO to active or inactive using an external control without the need to switch the supply voltage on and off. An external multiplex mode can be configured when Sonar-BEROs have to be switched on and off in sequence via the enabling input. In this case, it is ensured that the Sonar-BEROs will not interfere with each other. In contrast to internal multiplex mode, more than 10 Sonar-BEROs can be operated in multiplex mode.

Connection of the enable input:

- Sonar-BERO active
Enable input XI at L+ or open.
- Sonar-BERO not active
Enable input XI at DC 0 to 3 V

Advantages:

- Reliable protection against mutual interference.
- An object can be assigned to a BERO.

Disadvantages

- Additional connection overheads (e.g. a PLC).
- Longer response time than for a synchronization circuit because each BERO is only active briefly and then has to wait until all the other BEROs in the circuit have emitted.

Example: Recognition of narrow objects

Narrow objects are to be recognized and it shall be determined whether one, two or no objects are present.

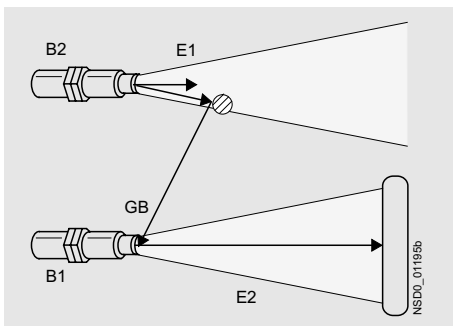

In this example, echo GB would cause BERO B1 to mistakenly detect an object. Synchronization of the BEROs would not help

here because echo pulse E2 would not arrive until after echo GB at BERO B1 and a BERO only ever detects the first echo. In this example, a PLC must be used to switch cyclically to and from between the two BEROs.

Internal multiplex mode

The Sonar-BEROs of compact ranges 0, II, III and M18 can be interconnected to form a network. Up to 10 devices (or 6 devices in the case of compact range 0) can be operated in series or parallel (see "Synchronization"). No additional electronics is required. The enable inputs of all the BEROs are simply connected together. On programming, each device is informed about the number of BEROs in the network as well as its own position (address) in the network. When they have been wired up and the supply voltage has been connected, the BEROs automatically operate in multiplex mode.

SONPROG interface device

Using the SONPROG 3RX4 000 interface device and the relevant software, the Sonar-BEROs of compact ranges II, III and M18 can be individually adapted to the respective application requirements. The device is an interface for the following tasks:

- Checking the parameters of the Sonar-BERO
- Modifying the parameters of the Sonar-BERO
- Aligning the Sonar-BERO to the application.

This enables a Sonar-BERO to be optimized specifically for an application. The adjustments found can be saved or printed out to facilitate maintenance and documentation of the equipment.

When a Sonar-BERO has been replaced, the new device can be programmed with the saved data quickly and easily. No new adjustments are necessary.

The main parameters that can be set are:

- Lower and upper limit of the operating range
- Differential travel
- Switching function NO or NC
- Switching frequency
- Lower and upper limit of the analog characteristic
- Analog characteristic, rising or falling
- End of close range
- End of sensing range
- Mean value generation
- Attenuation.

The function can also be set for the device:

- Multiplex function
- Temperature compensation
- Diffuse or reflex sensor.

For a detailed description of the possible settings, see "SONPROG interface device".

A special function mode enables the Sonar-BERO to be adapted to applications with level measurements. See "Compact range for pump control".

Adjustment with potentiometers

The potentiometers are used to select the required limits (min. or max.) of the switching range.

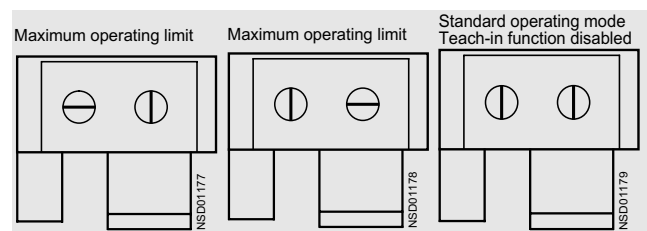

Circuit diagrams

Synchronization

NO function

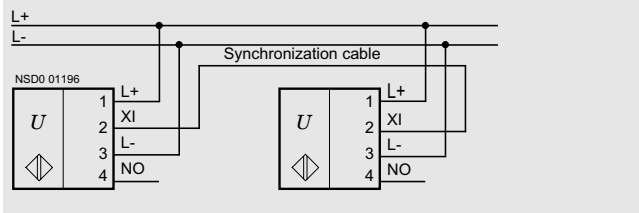

NC function

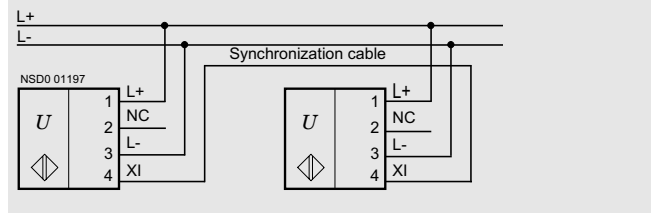

External multiplex mode

NO function

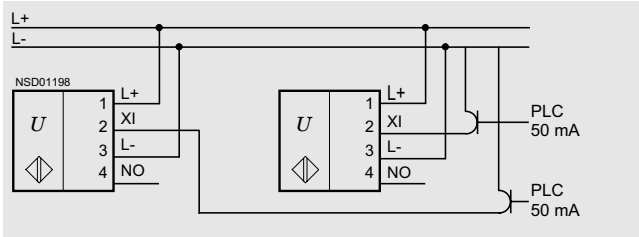

NC function

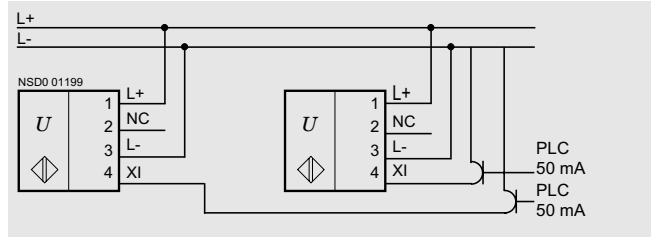

Internal multiplex mode (analog output)

NO function

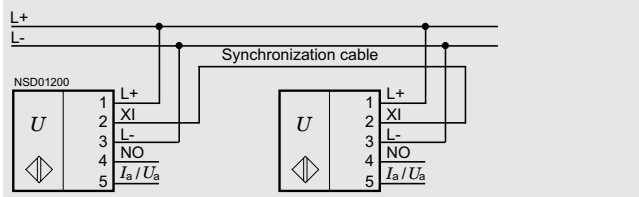

NC function

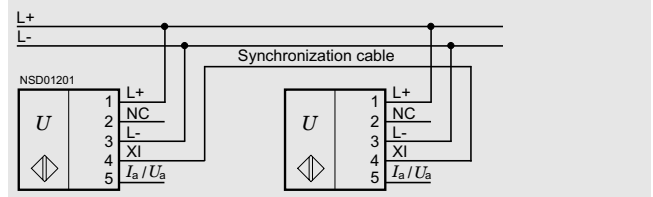

Characteristics

Sound cones

The following diagrams are the results of measurements with Sonar-BEROs, with their production-dependent scatter, at room conditions (20 °C). Standard reflectors moved radially are detected within the possible sensing range by the Sonar-BEROs.

The diagrams apply to the individual types of sensor for the defined reflectors and for larger reflectors.

- Measurement 1 with an aligned object, with the most optimum reflection ⇒ keep environment free of objects which should not be detected.
- Measurement 2 with an object which has partially aligned surfaces ⇒ detection of round materials and plates with rounded edges.
- Measurement 3 with an object with a plane surface moving perpendicularly to the sound cone ⇒ detection of plane surfaces and edges.

Defined reflectors:

- Measurements 1, 3: plane object
 - 2 cm × 2 cm, for sensors with sensing ranges up to 130 cm
 - 10 cm × 10 cm, for sensors with larger sensing ranges
- Measurement 2: cylindrical object, 8 cm diameter.

The following pages show the sound cones for the following designs:

- Compact range 0
- Sonar thru-beam sensor
- Compact range M18
- Compact range I, II, III (M30).

Sonar-BERO

Introduction

Compact range 0, sensing range 6 ... 30 cm

Measurement 1 (most optimum reflection), attenuation 0

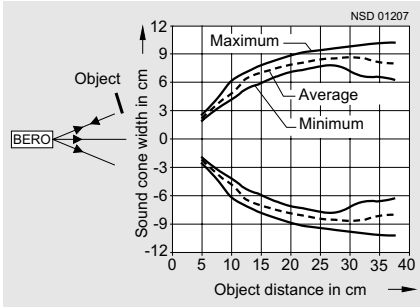

Measurement 2 (cylindrical object), attenuation 0

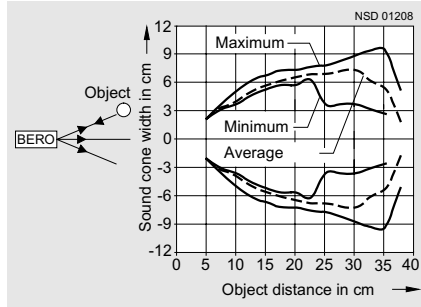

Measurement 3 (plane object), attenuation 0

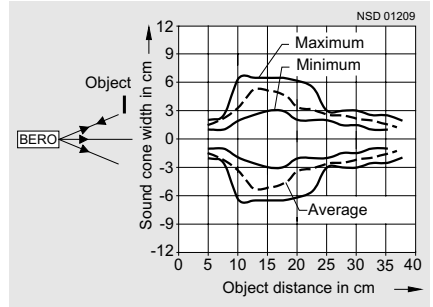

Compact range 0, sensing range 20 ... 100 cm

Measurement 1 (most optimum reflection), attenuation 0

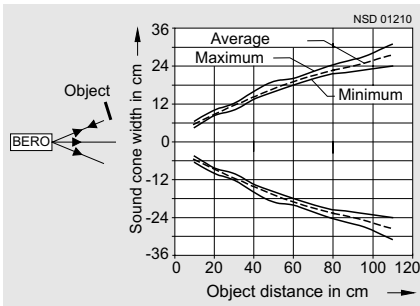

Measurement 2 (cylindrical object), attenuation 0

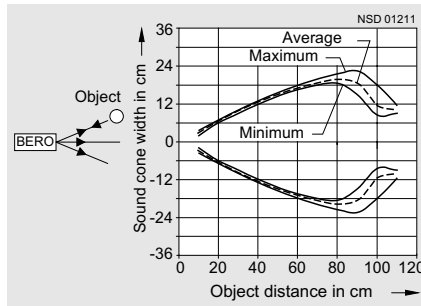

Measurement 3 (plane object), attenuation 0

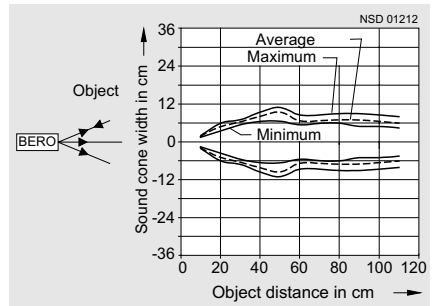

K 65 compact form, sensing range 25 ... 250 cm

Measurement 1 (most optimum reflection), attenuation 0

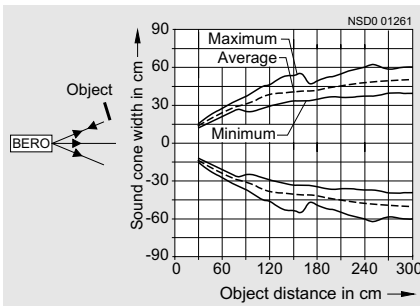

Measurement 2 (cylindrical object), attenuation 0

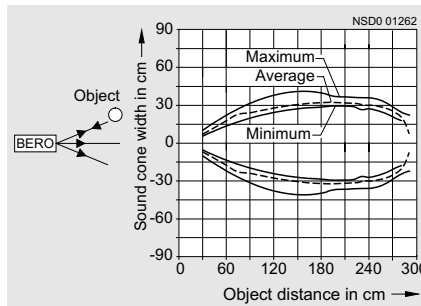

Measurement 3 (plane object), attenuation 0

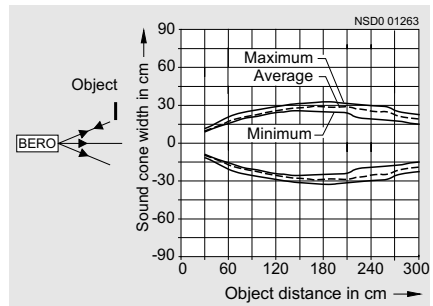

Sonar thru-beam sensor, sensing ranges 5 ... 40 cm, 5 ... 80 cm, 5 ... 150 cm

Receiver angle 0°

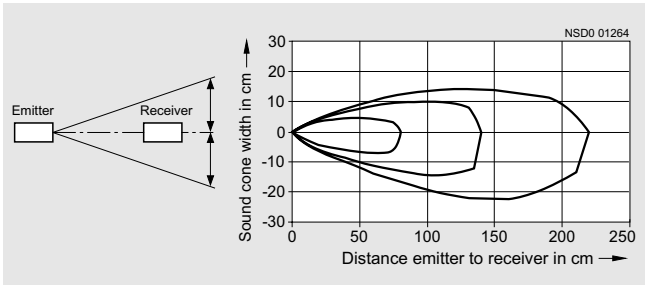

Variable receiver angle, optimally aligned

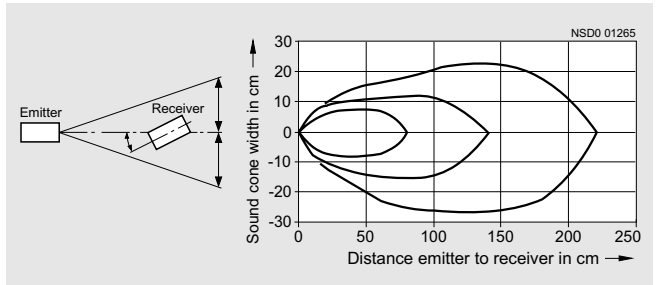

M18 compact range, sensing range 5 ... 30 cm

Measurement 1 (most optimum reflection), attenuation 0

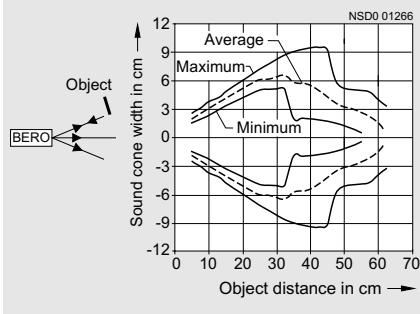

Measurement 2 (cylindrical object), attenuation 0

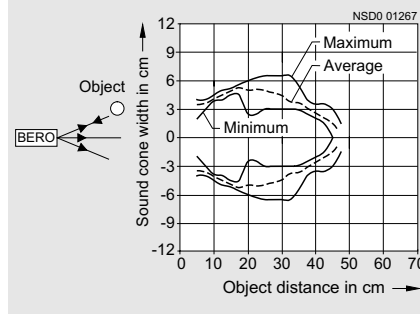

Measurement 3 (plane object), attenuation 0

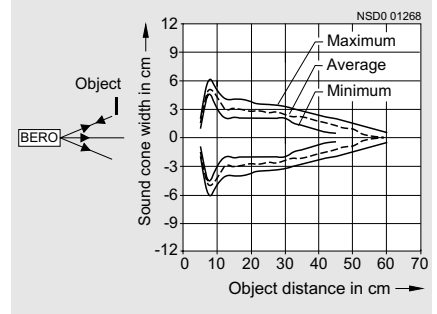

Measurement 1 (most optimum reflection), attenuation 2

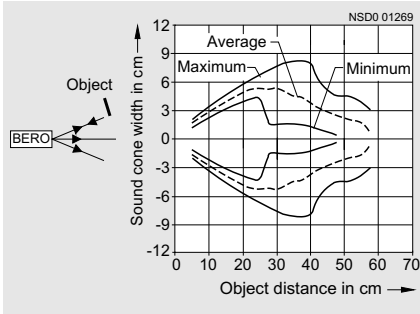

Measurement 2 (cylindrical object), attenuation 2

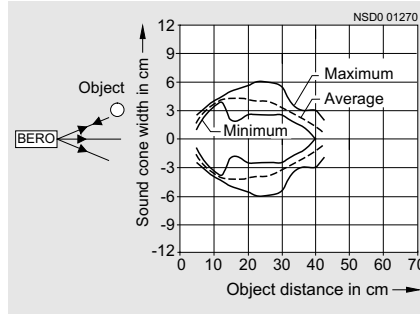

Measurement 3 (plane object), attenuation 2

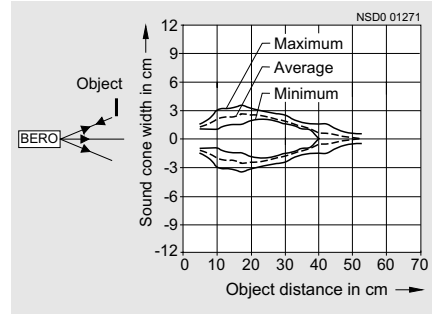

Measurement 1 (most optimum reflection), attenuation 4

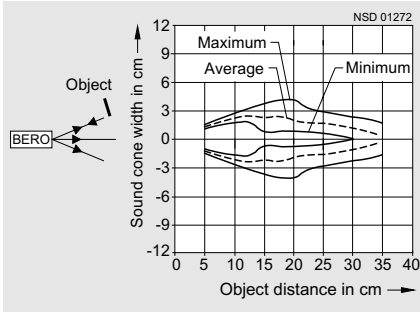

Measurement 2 (cylindrical object), attenuation 4

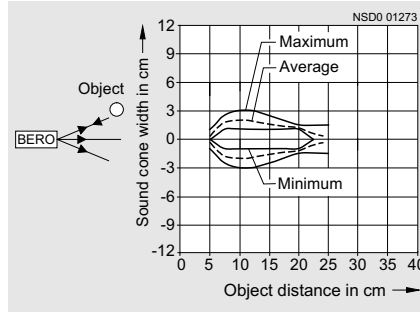

Measurement 3 (plane object), attenuation 4

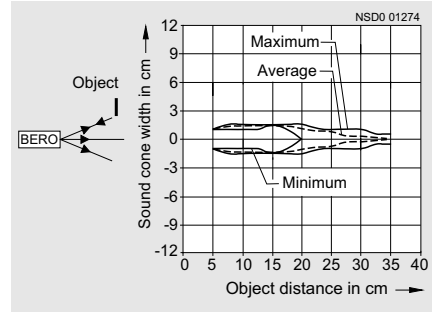

Measurement 1 (most optimum reflection), attenuation 6

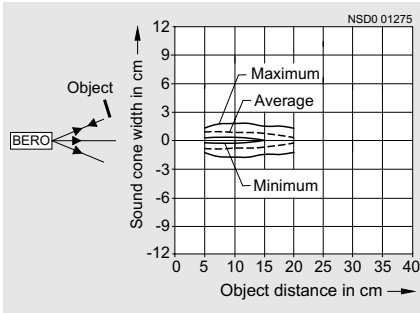

Measurement 2 (cylindrical object), attenuation 6



Measurement 3 (plane object), attenuation 6

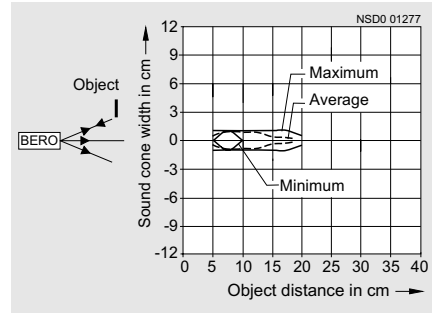

Sonar-BERO

Introduction

M18 compact range, sensing range 15 ... 100 cm

Measurement 1 (most optimum reflection), attenuation 0

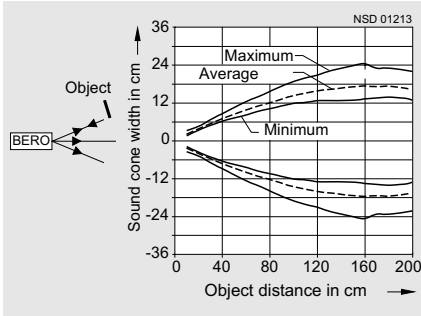

Measurement 2 (cylindrical object), attenuation 0

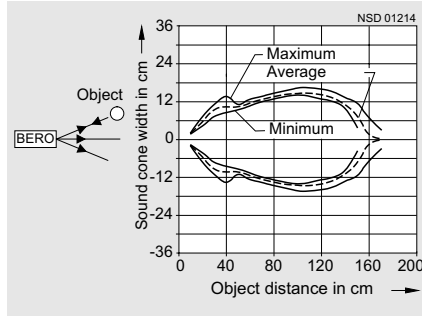

Measurement 3 (plane object), attenuation 0

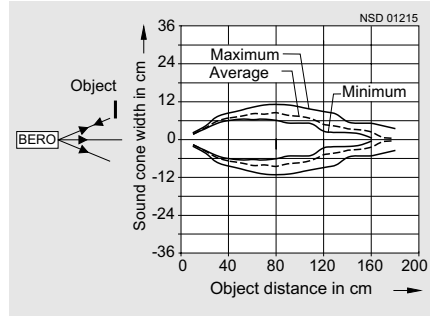

Measurement 1 (most optimum reflection), attenuation 2

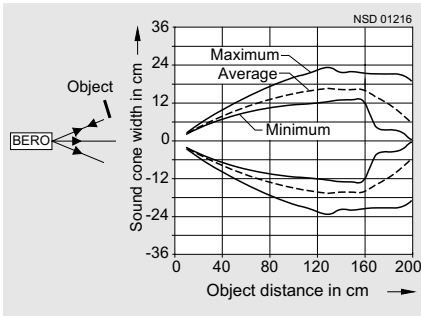

Measurement 2 (cylindrical object), attenuation 2

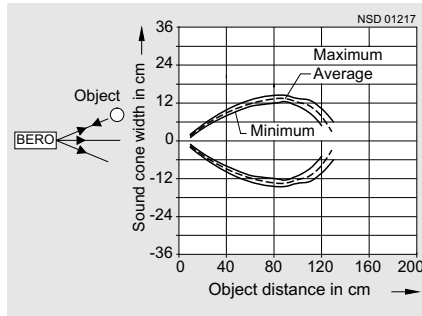

Measurement 3 (plane object), attenuation 2

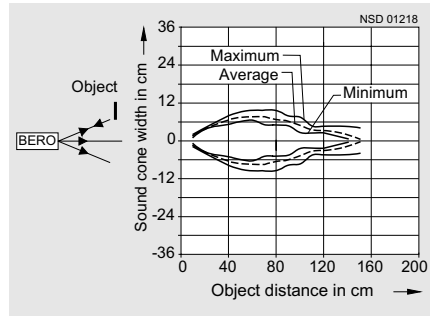

Measurement 1 (most optimum reflection), attenuation 4

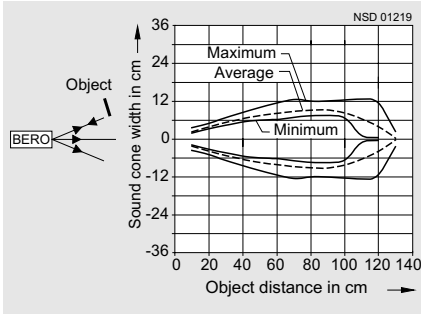

Measurement 2 (cylindrical object), attenuation 4

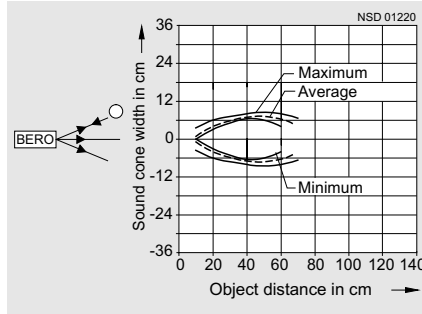

Measurement 3 (plane object), attenuation 4

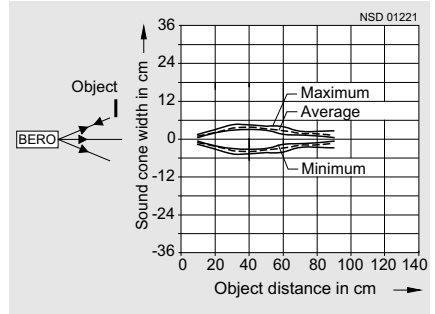

Measurement 1 (most optimum reflection), attenuation 6

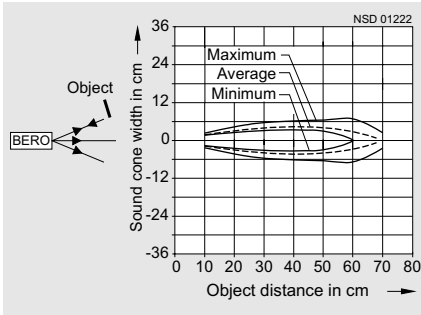

Measurement 2 (cylindrical object), attenuation 6

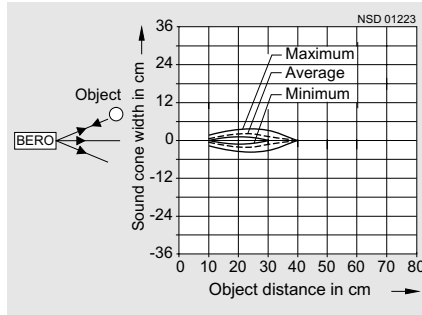

Measurement 3 (plane object), attenuation 6

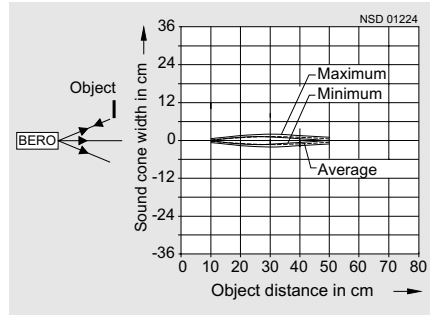

3

Compact ranges I to III, sensing range 6 ... 30 cm

Measurement 1 (most optimum reflection), attenuation 0

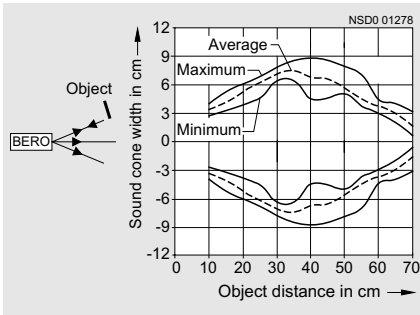

Measurement 2 (cylindrical object), attenuation 0

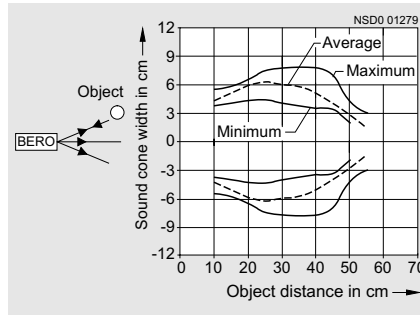

Measurement 3 (plane object), attenuation 0

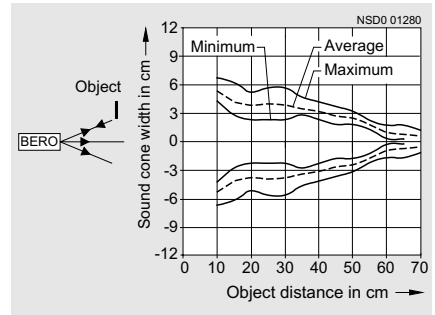

Measurement 1 (most optimum reflection), attenuation 2

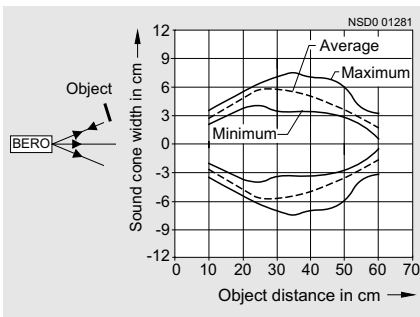

Measurement 2 (cylindrical object), attenuation 2

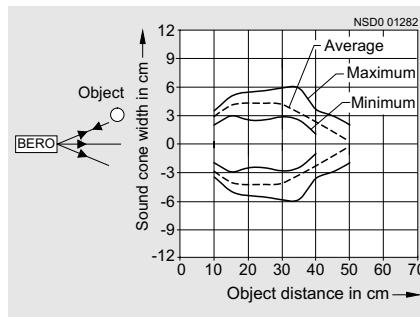

Measurement 3 (plane object), attenuation 2

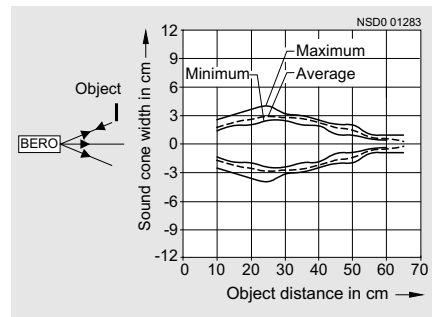

Measurement 1 (most optimum reflection), attenuation 4

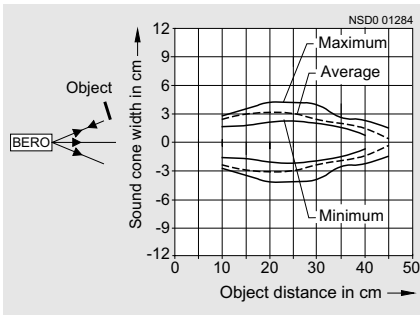

Measurement 2 (cylindrical object), attenuation 4

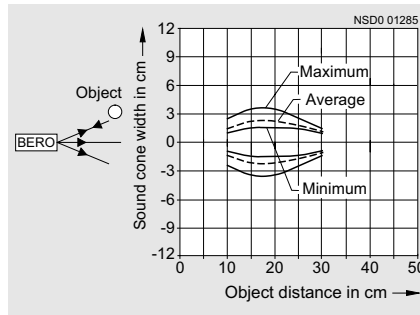

Measurement 3 (plane object), attenuation 4

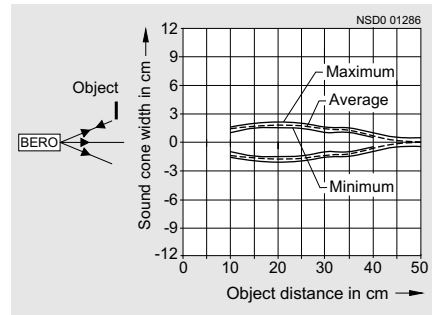

Measurement 1 (most optimum reflection), attenuation 6

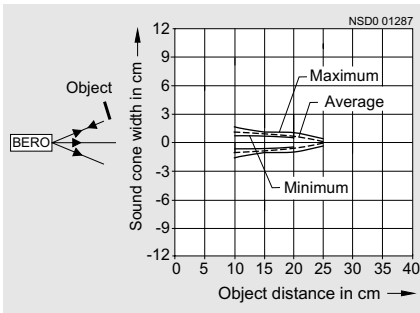

Measurement 2 (cylindrical object), attenuation 6

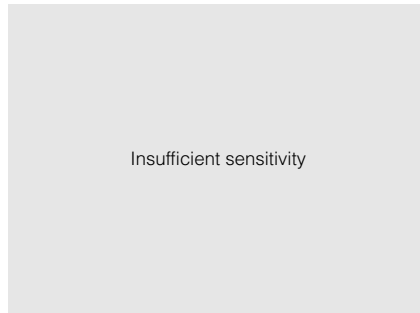

Measurement 3 (plane object), attenuation 6

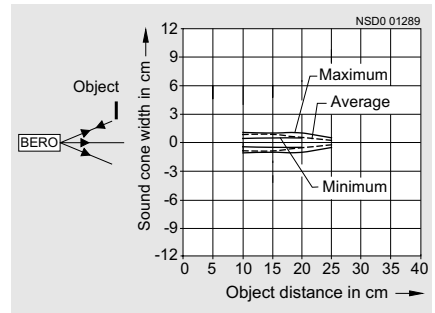

Note: only the sound cones with attenuation 0 apply to compact range I.

Introduction

Compact ranges I to III, sensing range 20 ... 130 cm

Measurement 1 (most optimum reflection), attenuation 0

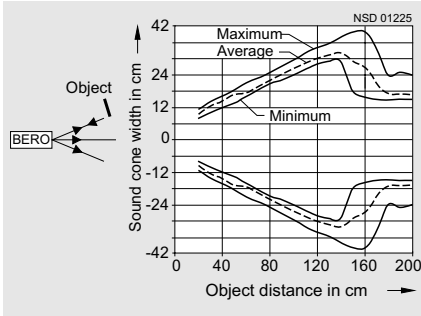

Measurement 2 (cylindrical object), attenuation 0

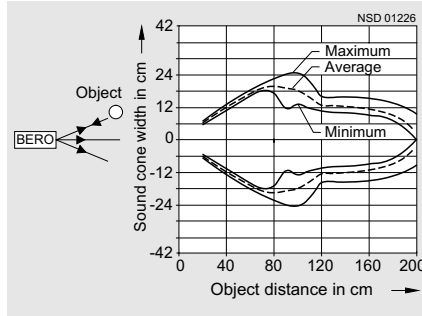

Measurement 3 (plane object), attenuation 0

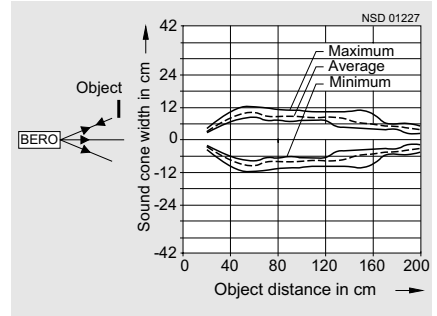

Measurement 1 (most optimum reflection), attenuation 2

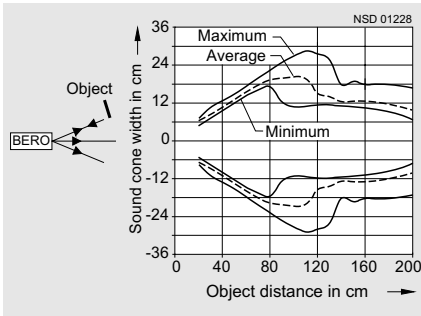

Measurement 2 (cylindrical object), attenuation 2

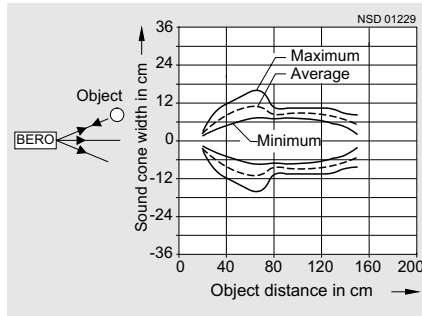

Measurement 3 (plane object), attenuation 2

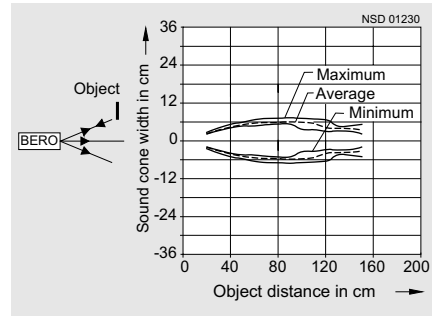

Measurement 1 (most optimum reflection), attenuation 4

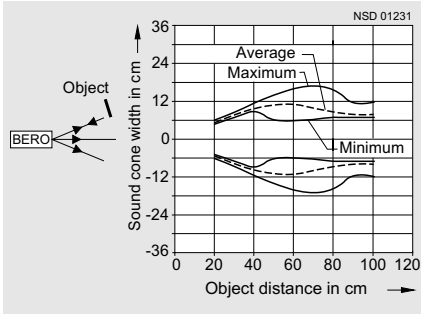

Measurement 2 (cylindrical object), attenuation 4

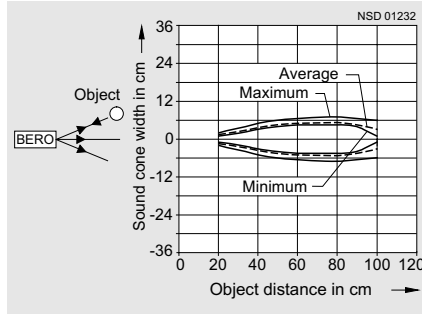

Measurement 3 (plane object), attenuation 4

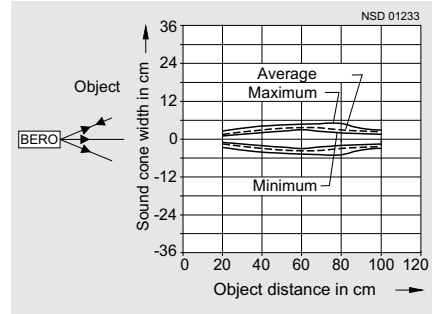

Measurement 1 (most optimum reflection), attenuation 6

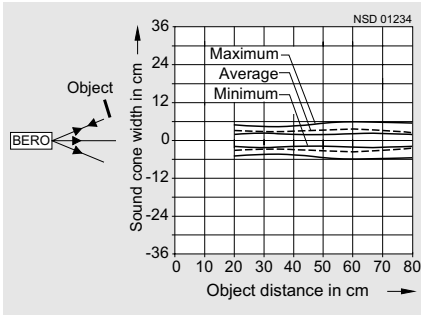

Measurement 2 (cylindrical object), attenuation 6



Measurement 3 (plane object), attenuation 6

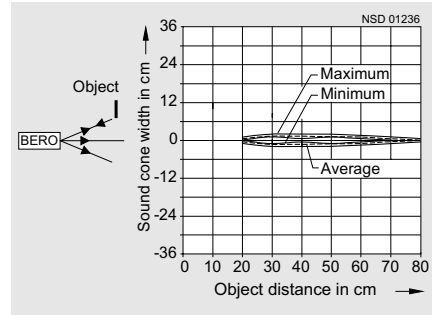

Note: only the sound cones with attenuation 0 apply to compact range I.

Compact ranges I to III, sensing range 40 ... 300 cm

Measurement 1 (most optimum reflection), attenuation 0

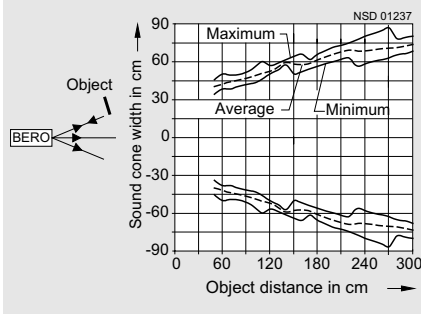

Measurement 2 (cylindrical object), attenuation 0

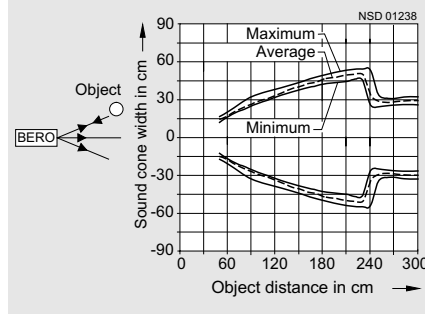

Measurement 3 (plane object), attenuation 0

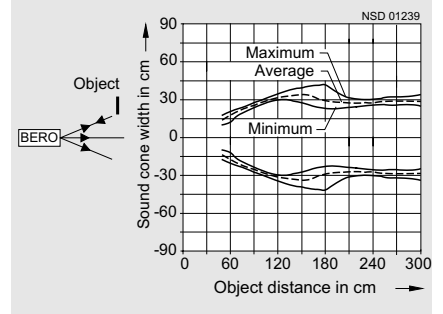

Measurement 1 (most optimum reflection), attenuation 2

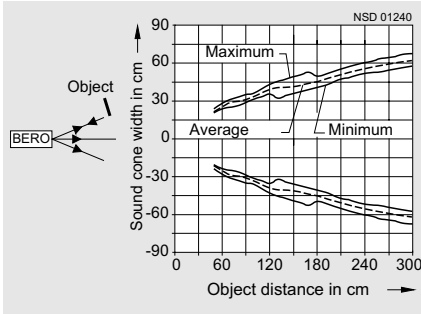

Measurement 2 (cylindrical object), attenuation 2

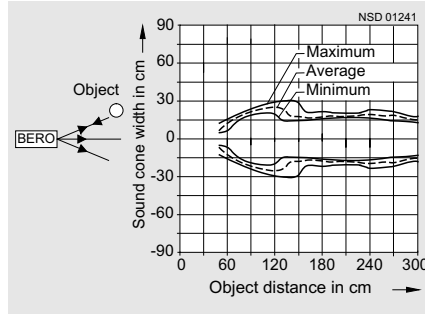

Measurement 3 (plane object), attenuation 2

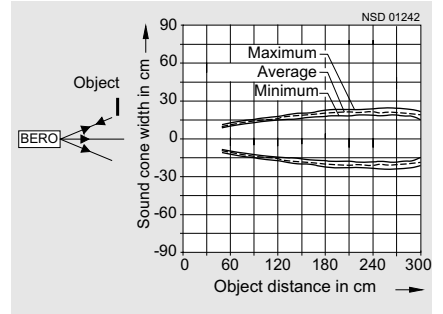

Measurement 1 (most optimum reflection), attenuation 4

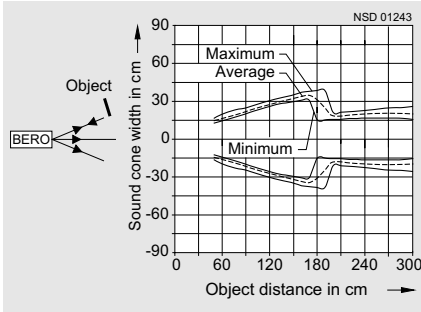

Measurement 2 (cylindrical object), attenuation 4

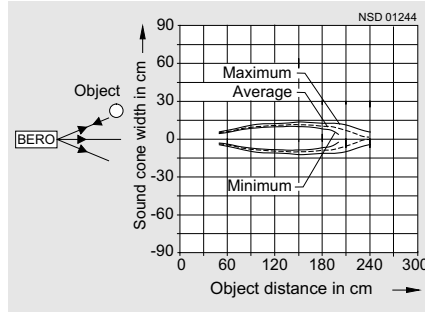

Measurement 3 (plane object), attenuation 4

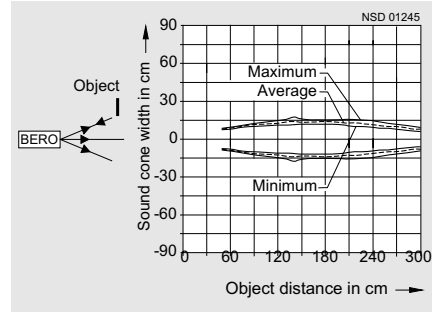

Measurement 1 (most optimum reflection), attenuation 6

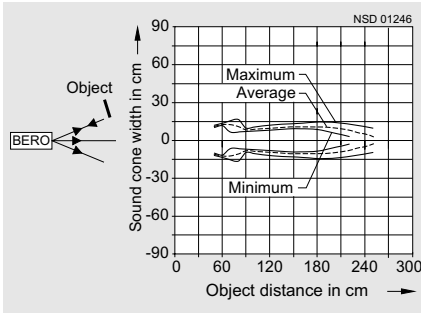

Measurement 2 (cylindrical object), attenuation 6

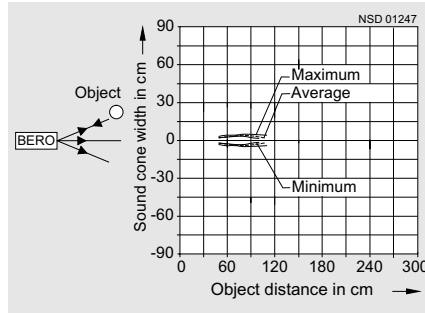

Measurement 3 (plane object), attenuation 6

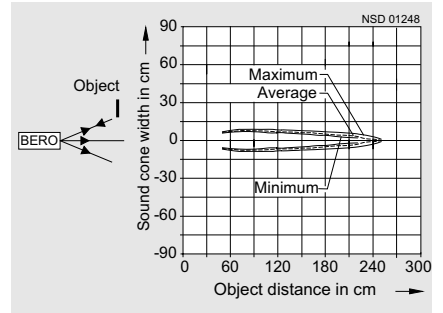

Note: only the sound cones with attenuation 0 apply to compact range I.

Sonar-BERO

Introduction

Compact ranges I to III, sensing range 60 ... 600 cm

Measurement 1 (most optimum reflection), attenuation 0

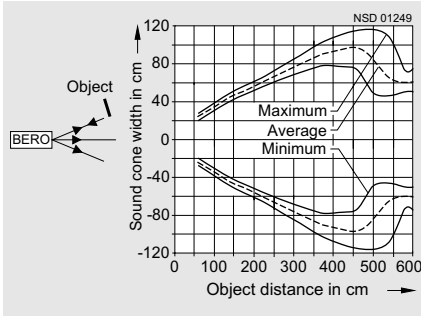

Measurement 2 (cylindrical object), attenuation 0

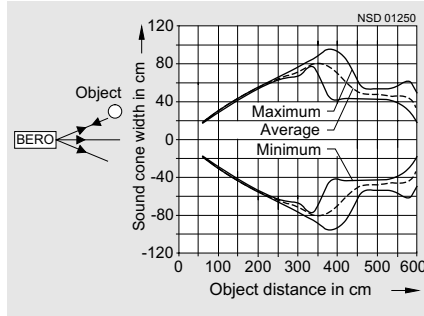

Measurement 3 (plane object), attenuation 0

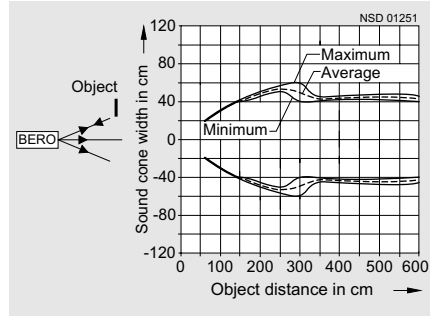

Measurement 1 (most optimum reflection), attenuation 2

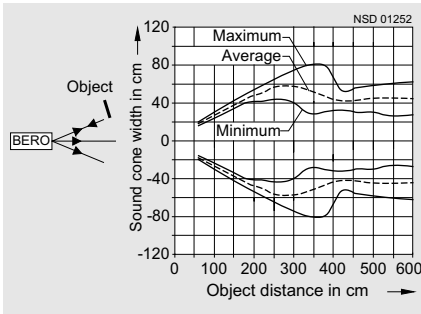

Measurement 2 (cylindrical object), attenuation 2

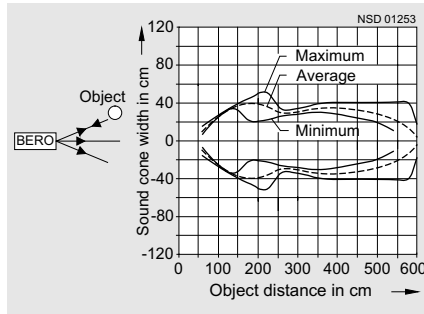

Measurement 3 (plane object), attenuation 2

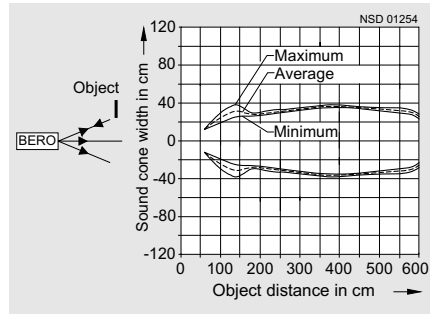

Measurement 1 (most optimum reflection), attenuation 4

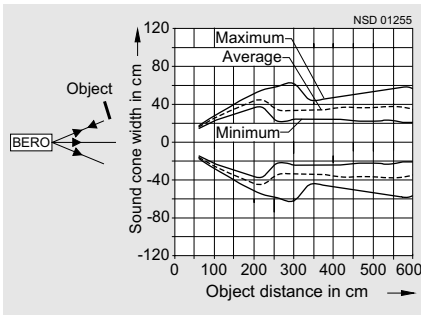

Measurement 2 (cylindrical object), attenuation 4

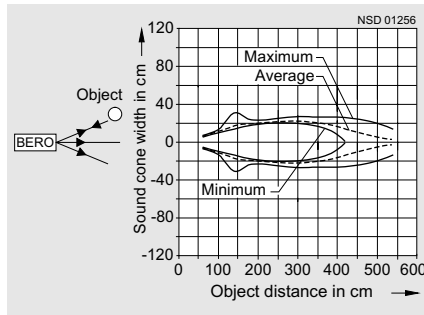

Measurement 3 (plane object), attenuation 4

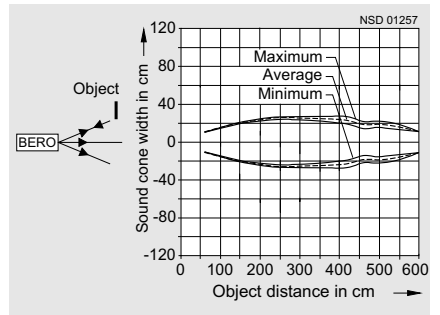

Measurement 1 (most optimum reflection), attenuation 6

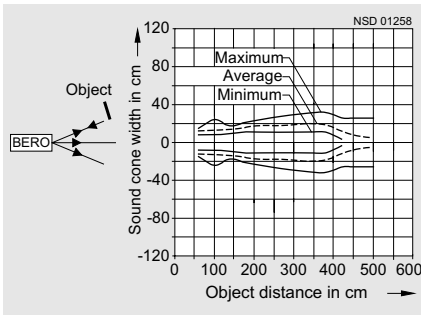

Measurement 2 (cylindrical object), attenuation 6

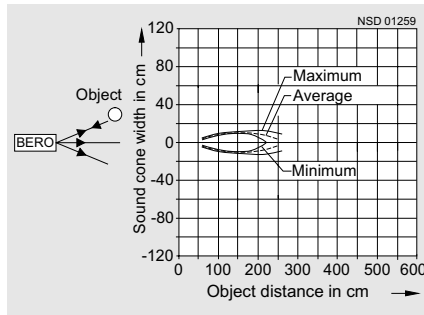

Measurement 3 (plane object), attenuation 6

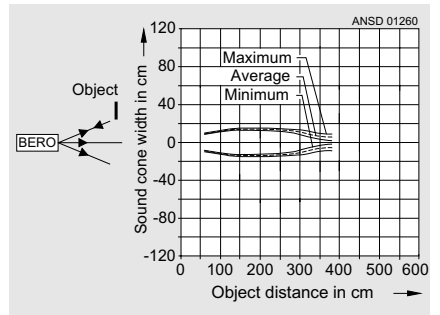

Note: only the sound cones with attenuation 0 apply to compact range I.

3

Further information**Active surface**

The active surface of an ultrasonic proximity switch is the surface at which the ultrasound is emitted and received (IEC).

Reference axis

The reference axis is the axis running perpendicular to the active surface and through its center (IEC).

Sensing range

The sensing range is understood to be the range within which the operating distance can be set (IEC).

With the Sonar-BEROs, this is a range from 5 cm to 10 m depending on the type.

The construction of the sensor causes the ultrasonic beam to be emitted in the shape of a cone. Reflecting objects are only detected within this sound cone. Within the blind zone, which lies between the sensor surface and the sensing range, echoes cannot be evaluated for physical reasons.

Operating distance

The operating distance is the distance at which a target approaching the active surface along the reference axis causes a signal change at the output (IEC).

Rated operating distance s_n

The rated operating distance is a conventional variable for defining the operating distances. Neither specimen scatter nor changes resulting from external influences such as voltage or temperature are taken into account (IEC).

Real operating distance s_r

The real operating distance is the operating distance of a particular proximity switch measured at defined temperature, voltage and mounting conditions (IEC).

Accuracy

The accuracy is the permissible error that exists as the difference between the true distance and the indicated value. The accuracy of a Sonar-BERO depends on internal tolerances as well as certain physical parameters of the air such as humidity, atmospheric pressure and air movement. These parameters influence the sound propagation time and therefore the measured value received.

Atmospheric pressure

Any other atmospheric changes at a permanent site will have a negligible effect on the sound propagation time. Between sea level and 3000 m altitude, the speed of sound is reduced by less than 1 %. Sound propagation is not possible in a vacuum.

Air humidity

At room temperature and at lower temperatures, the humidity will have a negligible effect on the sound propagation time. At higher temperatures, the speed of sound increases with humidity.

Air temperature

The sound propagation time is dependent on the air temperature. An air temperature of 20 °C is used as the reference variable here. The speed of sound changes with air temperature by 0.17 %/K. This temperature dependent change in sound propagation time means that as the temperature increases, the distance to the object appears to become shorter.

A change in temperature of, for example, +10 °C results in a change in the speed of sound of approximately +1.75 % and therefore a change in the operating distance of +1.75 %.

Gas types

The Sonar-BERO is designed for operation in atmospheric air. If it is operated in other gases, different values for the speed of sound and attenuation can result in significant measurement errors and even malfunction (e.g. in carbon dioxide).

Air currents

Changes to the speed of sound as a result of constant changes in the flow direction and flow velocity of the air cannot be quantified by means of a generally applicable formula. High-temperature objects, such as glowing metal cause air turbulence. This will scatter or deflect the ultrasound. An echo will not be generated that can be evaluated.

The measured results are not affected by, e.g.:

Precipitation

Average levels of precipitation in the form of rain or snow will not adversely affect the functionality of the Sonar-BERO. The transducer surface should not, however, be wetted. Dewing is permissible.

Paint spray

This has no determinable effect on the functioning of the Sonar-BERO. To prevent any detrimental effect on the sensitivity of the transducer, however, the paint spray must not be allowed to settle on the active transducer surface.

External sound

External sound is distinguished from the system-specific echoes and does not usually cause malfunctions.

Repeat accuracy R

The repeat accuracy is the change in the real operating distance s_r at defined conditions (IEC).

The repeat accuracy is measured over a period of 8 hours at an ambient temperature of 23 °C (± 5 °C), any relative humidity within the specified range, and a defined supply voltage.

The repeat accuracy of the Sonar-BERO is 0.15 % of full-scale.

Sonar-BERO

Compact ranges I to III

Overview



M30 form with fixed sensor

The Sonar-BEROs of compact ranges I, II and III are ready-to-use all-in-one units with a cylindrical M30 enclosure. They differ with regard to their range, their functional scope and their adjustment or programming capability.

Design

Standard version

In the standard version, the devices have a permanently installed sensor.

Version with separate sensor



M30 form with separate sensor

Due to its small dimensions, the sensor is especially suitable in confined spaces.

The ultrasonic sensor is installed in a cylindrical enclosure separated from the other electronics. In devices of type 3RG6. 12, the sensor is installed in an M18 shell and in devices of type 3RG6. 13 it is installed in an M30 shell with a length of 25 mm in both cases.

Two nuts are supplied for fixing. The connecting lead of 1.6 m in length is cast onto the sensor. The connection to the evaluation electronics located in the M30 enclosure of the compact range is established via the preassembled coaxial cable plug. The mating socket is installed on the end face of the enclosure.

Version with swivel sensor

These devices correspond functionally to the other devices of compact ranges I to III. They are particularly suitable for applications where the standard types cannot be used due to space limitations.



M30 form with swivel sensor

The ultrasonic sensor is hinged with a swivel arm to the tubular enclosure of the signal evaluator. This allows rotation about the cylinder axes as well as perpendicular movement at about 100° to the cylinder axis.

Reflector

With the Sonar-BEROs of compact ranges I to III, a 3RX1 910 passive reflector can be clamped onto the sensor head (see "Accessories").

Where space is limited, objects can be detected which are perpendicular to the Sonar-BERO (which reduces the installation depth). The blind zone is then reduced by about 6 cm.

Functions

Range definition and adjustability

Objects within the preset operating range or analog range will be reliably detected causing the switching output or analog output to change state.

The blind zone must be kept clear of any objects since this might cause false outputs. Objects at a distance from the sensor that is outside the operating range limits will not be signaled at the switching output.

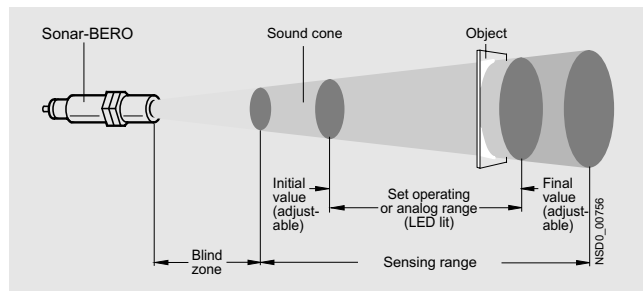

Sound cone

Operating modes

Standard operating mode: diffuse sensor

An object entering the sound cone from any direction causes the output signal to change when it enters the preset sensing range.

Reflex sensor

If a reflector is permanently fixed within a set operating range, the Sonar-BERO will be operated by all objects that lie between the Sonar-BERO and the reflector even those that absorb sound.

Thru-beam sensor

(Compact ranges II and III only)

The Sonar-BERO only evaluates whether or not an object is located between the emitter and the receiver. The range of the arrangement is twice that of a single sensor.

Active measurement system

The propagation time of the ultrasonic signal is evaluated in order to determine the distance between the emitter and the receiver. The range of the arrangement is twice that of a single sensor. The system is insensitive to objects in the measurement path as long as they do not totally shield the ultrasonic pulses of the emitter from the receiver.

Programming

SONPROG For optimizing to the operating conditions, all sensors of compact ranges II and III can be programmed using a PC and the SONPROG 3RX4 000 interface device.

The main parameters that can be changed are:

- Lower and upper limit of the operating range
- Differential travel
- Switching function NO or NC
- Switching frequency
- Lower and upper limit of the analog range
- Analog characteristic, rising or falling
- End of close range
- End of sensing range
- Mean value generation
- Multiplex function
- Temperature compensation
- Susceptibility.

The proximity switches can also be ordered with non-standard values. These values must be specified in plain text on ordering.

Technical specifications

Type	3RG60 .2, 3RG61 .2	3RG60 .3, 3RG61 .3	3RG60 .5, 3RG61 .5	3RG60 .4, 3RG61 .4	3RG61 76
Sensing range	cm 6 ... 30	20 ... 130	40 ... 300	60 ... 600	80 ... 1000
Standard target	cm 1 × 1	2 × 2	5 × 5	10 × 10	10 × 10
Differential travel <i>H</i>	mm 10	10	20	60	80
Repeat accuracy <i>R</i>	mm ± 0.45	± 2	± 5	± 9	± 15
Operational voltage (DC)	V 12 ... 30 (including ± 10 % residual ripple, at 12 ... 20 V susceptibility falls by approx. 20 %)				
Rated operational current <i>I_e</i>					
• NO contact	mA 300				300
• NC contact	mA 150 or 300 (see selection and ordering data)				150
No-load supply current <i>I₀</i>	mA Max. 50				Max. 75
Ultrasonic frequency <i>f</i>	kHz 400		200	120	80
Switching frequency	Hz 8		4	2	1
Response time	ms 80		110	200	400
Power-up delay <i>t_v</i>	ms 280		280	280	280
Switching status display	Yellow LED				
Enclosure material	Brass, nickel-plated; CRAFTIN converter cover; epoxy resin converter surface				CRASTIN; epoxy resin converter surface
Degree of protection	IP65; IP68 with separate sensor		IP65		IP65
Ambient temperature					
• During operation	°C	-25 ... +70			
• During storage	°C	-40 ... +85			





Sonar-BERO



Compact range III

Overview

- Operates as diffuse sensor, reflex sensor or through-beam sensor
 - Adjustable using 2 potentiometers, with SONPROG ¹⁾ or per teach-in
 - Foreground and background suppression
 - Synchronization capability, multiplex operation
 - Temperature compensation
 - Solid-state outputs:
 - Switching output
 - Analog output
 - Connection via M12, 5-pin connector
- 1) Parameters can be preset to non-standard values. A programming supplement will be charged in this case per unit.

Selection and ordering data

	Sensing range		Rated operational current	Switching output	Analog output	DT	Order No.	PS	Approx. weight per PU kg
	cm		mA	pnp					
Fixed sensor									
 3RG61 12-3..00	6 ... 30		300	1 NO	4 ... 20 mA	▶	3RG61 12-3BF00	1 unit	0.239
	20 ... 130		300	1 NO	4 ... 20 mA	▶	3RG61 13-3BF00	1 unit	0.242
	40 ... 300		300	1 NO	4 ... 20 mA	▶	3RG61 15-3BF00	1 unit	0.337
	60 ... 600		300	1 NO	4 ... 20 mA	▶	3RG61 14-3BF00	1 unit	0.419
	80 ... 1000		300	2 NO	4 ... 20 mA	C	3RG61 76-6BH00	1 unit	2.000
 3RG61 13-3..00	6 ... 30		150	1 NC	4 ... 20 mA	C	3RG61 12-3BE00	1 unit	0.245
	20 ... 130		150	1 NC	4 ... 20 mA	C	3RG61 13-3BE00	1 unit	0.242
	40 ... 300		150	1 NC	4 ... 20 mA	C	3RG61 15-3BE00	1 unit	0.334
	60 ... 600		150	1 NC	4 ... 20 mA	C	3RG61 14-3BE00	1 unit	0.417
	80 ... 1000		150	2 NC	4 ... 20 mA	C	3RG61 76-6BG00	1 unit	1.990
 3RG61 15-3..00	6 ... 30		300	1 NO	0 ... 20 mA	C	3RG61 12-3CF00	1 unit	0.239
	20 ... 130		300	1 NO	0 ... 20 mA	C	3RG61 13-3CF00	1 unit	0.240
	40 ... 300		300	1 NO	0 ... 20 mA	C	3RG61 15-3CF00	1 unit	0.340
	60 ... 600		300	1 NO	0 ... 20 mA	C	3RG61 14-3CF00	1 unit	0.416
	80 ... 1000		300	2 NO	0 ... 20 mA	C	3RG61 76-6CH00	1 unit	1.990
 3RG61 14-3..00	6 ... 30		150	1 NC	0 ... 20 mA	C	3RG61 12-3CE00	1 unit	0.235
	20 ... 130		150	1 NC	0 ... 20 mA	C	3RG61 13-3CE00	1 unit	0.238
	40 ... 300		150	1 NC	0 ... 20 mA	C	3RG61 15-3CE00	1 unit	0.330
	60 ... 600		150	1 NC	0 ... 20 mA	C	3RG61 14-3CE00	1 unit	0.423
	80 ... 1000		150	2 NC	0 ... 20 mA	C	3RG61 76-6CG00	1 unit	2.060
 3RG61 76-6..00	6 ... 30		300	1 NO	0 ... 10 V	▶	3RG61 12-3GF00	1 unit	0.237
	20 ... 130		300	1 NO	0 ... 10 V	▶	3RG61 13-3GF00	1 unit	0.239
	40 ... 300		300	1 NO	0 ... 10 V	▶	3RG61 15-3GF00	1 unit	0.338
	60 ... 600		300	1 NO	0 ... 10 V	▶	3RG61 14-3GF00	1 unit	0.425
	80 ... 1000		300	2 NO	0 ... 10 V	C	3RG61 76-6GH00	1 unit	2.140
	6 ... 30		150	1 NC	0 ... 10 V	C	3RG61 12-3GE00	1 unit	0.233
	20 ... 130		150	1 NC	0 ... 10 V	C	3RG61 13-3GE00	1 unit	0.247
	40 ... 300		150	1 NC	0 ... 10 V	C	3RG61 15-3GE00	1 unit	0.338
	60 ... 600		150	1 NC	0 ... 10 V	C	3RG61 14-3GE00	1 unit	0.420
	80 ... 1000		150	2 NC	0 ... 10 V	C	3RG61 76-6GG00	1 unit	2.160

	Sensing range		Rated operational current	Switching output	Analog output	DT	Order No.	PS	Approx. weight per PU	
	cm		mA	pnp					kg	
Swivel sensor										
	3RG61 25-3..00	6 ... 30	300	1 NO	4 ... 20 mA	C	3RG61 22-3BF00	1 unit	0.315	
		20 ... 130	300	1 NO	4 ... 20 mA	A	3RG61 23-3BF00	1 unit	0.315	
		40 ... 300	300	1 NO	4 ... 20 mA	C	3RG61 25-3BF00	1 unit	0.377	
		60 ... 600	300	1 NO	4 ... 20 mA	C	3RG61 24-3BF00	1 unit	0.461	
		6 ... 30	150	1 NC	4 ... 20 mA	C	3RG61 22-3BE00	1 unit	0.313	
		20 ... 130	150	1 NC	4 ... 20 mA	C	3RG61 23-3BE00	1 unit	0.318	
		40 ... 300	150	1 NC	4 ... 20 mA	C	3RG61 25-3BE00	1 unit	0.384	
		60 ... 600	150	1 NC	4 ... 20 mA	C	3RG61 24-3BE00	1 unit	0.455	
		6 ... 30	300	1 NO	0 ... 20 mA	C	3RG61 22-3CF00	1 unit	0.316	
		20 ... 130	300	1 NO	0 ... 20 mA	C	3RG61 23-3CF00	1 unit	0.310	
		40 ... 300	300	1 NO	0 ... 20 mA	C	3RG61 25-3CF00	1 unit	0.378	
		60 ... 600	300	1 NO	0 ... 20 mA	C	3RG61 24-3CF00	1 unit	0.454	
		6 ... 30	150	1 NC	0 ... 20 mA	C	3RG61 22-3CE00	1 unit	0.283	
		20 ... 130	150	1 NC	0 ... 20 mA	C	3RG61 23-3CE00	1 unit	0.330	
		40 ... 300	150	1 NC	0 ... 20 mA	C	3RG61 25-3CE00	1 unit	0.375	
		60 ... 600	150	1 NC	0 ... 20 mA	C	3RG61 24-3CE00	1 unit	0.455	
		6 ... 30	300	1 NO	0 ... 10 V	C	3RG61 22-3GF00	1 unit	0.314	
		20 ... 130	300	1 NO	0 ... 10 V	C	3RG61 23-3GF00	1 unit	0.314	
		40 ... 300	300	1 NO	0 ... 10 V	C	3RG61 25-3GF00	1 unit	0.378	
		60 ... 600	300	1 NO	0 ... 10 V	C	3RG61 24-3GF00	1 unit	0.450	
		6 ... 30	150	1 NC	0 ... 10 V	C	3RG61 22-3GE00	1 unit	0.310	
		20 ... 130	150	1 NC	0 ... 10 V	C	3RG61 23-3GE00	1 unit	0.315	
		40 ... 300	150	1 NC	0 ... 10 V	C	3RG61 25-3GE00	1 unit	0.374	
		60 ... 600	150	1 NC	0 ... 10 V	C	3RG61 24-3GE00	1 unit	0.450	
Separate sensor										
	3RG61 12-3..01	6 ... 30	300	1 NO	4 ... 20 mA	C	3RG61 12-3BF01	1 unit	0.335	
		20 ... 130	300	1 NO	4 ... 20 mA	C	3RG61 13-3BF01	1 unit	0.380	
		6 ... 30	150	1 NC	4 ... 20 mA	C	3RG61 12-3BE01	1 unit	0.325	
		20 ... 130	150	1 NC	4 ... 20 mA	C	3RG61 13-3BE01	1 unit	0.375	
		6 ... 30	300	1 NO	0 ... 20 mA	C	3RG61 12-3CF01	1 unit	0.330	
		20 ... 130	300	1 NO	0 ... 20 mA	C	3RG61 13-3CF01	1 unit	0.377	
		6 ... 30	150	1 NC	0 ... 20 mA	C	3RG61 12-3CE01	1 unit	0.350	
		20 ... 130	150	1 NC	0 ... 20 mA	C	3RG61 13-3CE01	1 unit	0.370	
		6 ... 30	300	1 NO	0 ... 10 V	C	3RG61 12-3GF01	1 unit	0.340	
		20 ... 130	300	1 NO	0 ... 10 V	C	3RG61 13-3GF01	1 unit	0.385	
		6 ... 30	150	1 NC	0 ... 10 V	C	3RG61 12-3GE01	1 unit	0.340	
		20 ... 130	150	1 NC	0 ... 10 V	C	3RG61 13-3GE01	1 unit	0.376	
	Accessories									
		SONPROG interface device, AC 100 ... 240 V, DC 24 V					A	3RX4 000	1 unit	0.684

Sonar-BERO

Compact range II

Overview







- Operates as diffuse sensor, reflex sensor or through-beam sensor
- Adjustable using 2 potentiometers, with SONPROG 1) or per teach-in
- Foreground and background suppression
- Synchronization capability, multiplex operation
- Temperature compensation

- Solid-state outputs:
 - 1 or 2 switching outputs
 - Frequency output, suitable for connection to LOGO!

- Connection via M12 connector
 - 4-pole (with 1 output)
 - 5-pole (with 2 outputs)

1) Parameters can be preset to non-standard values. A programming supplement will be charged in this case per unit.







Selection and ordering data

	Sensing range		Rated operational current	Switching output	Frequency output	DT	Order No.	PS	Approx. weight per PU kg
	cm		mA	pnp					
Fixed sensor									
 3RG60 12-3.00	6 ... 30		300	1 NO	–	▶	3RG60 12-3AF00	1 unit	0.239
	20 ... 130		300	1 NO	–	▶	3RG60 13-3AF00	1 unit	0.241
	40 ... 300		300	1 NO	–	▶	3RG60 15-3AF00	1 unit	0.336
	60 ... 600		300	1 NO	–	▶	3RG60 14-3AF00	1 unit	0.421
 3RG60 13-3.00	6 ... 30		300	1 NC	–	C	3RG60 12-3AE00	1 unit	0.235
	20 ... 130		300	1 NC	–	▶	3RG60 13-3AE00	1 unit	0.243
	40 ... 300		300	1 NC	–	▶	3RG60 15-3AE00	1 unit	0.337
	60 ... 600		300	1 NC	–	C	3RG60 14-3AE00	1 unit	0.415
 3RG60 15-3.00	6 ... 30		300	2 NO	–	▶	3RG60 12-3AH00	1 unit	0.238
	20 ... 130		300	2 NO	–	▶	3RG60 13-3AH00	1 unit	0.242
	40 ... 300		300	2 NO	–	▶	3RG60 15-3AH00	1 unit	0.340
	60 ... 600		300	2 NO	–	▶	3RG60 14-3AH00	1 unit	0.422
 3RG60 14-3.00	6 ... 30		300	2 NC	–	C	3RG60 12-3AG00	1 unit	0.240
	20 ... 130		300	2 NC	–	C	3RG60 13-3AG00	1 unit	0.240
	40 ... 300		300	2 NC	–	C	3RG60 15-3AG00	1 unit	0.336
	60 ... 600		300	2 NC	–	C	3RG60 14-3AG00	1 unit	0.419
	6 ... 30		300	–	30 ... 150 Hz	C	3RG60 12-3RS00	1 unit	0.237
	20 ... 130		300	–	20 ... 130 Hz	C	3RG60 13-3RS00	1 unit	0.240
	40 ... 300		300	–	20 ... 150 Hz	C	3RG60 15-3RS00	1 unit	0.334
	60 ... 600		300	–	15 ... 150 Hz	C	3RG60 14-3RS00	1 unit	0.424
Swivel sensor									
 3RG60 25-3.00	6 ... 30		300	1 NO	–	C	3RG60 22-3AF00	1 unit	0.314
	20 ... 130		300	1 NO	–	C	3RG60 23-3AF00	1 unit	0.312
	40 ... 300		300	1 NO	–	C	3RG60 25-3AF00	1 unit	0.375
	60 ... 600		300	1 NO	–	C	3RG60 24-3AF00	1 unit	0.463
	6 ... 30		300	1 NC	–	C	3RG60 22-3AE00	1 unit	0.310
	20 ... 130		300	1 NC	–	C	3RG60 23-3AE00	1 unit	0.312
	40 ... 300		300	1 NC	–	C	3RG60 25-3AE00	1 unit	0.375
	60 ... 600		300	1 NC	–	C	3RG60 24-3AE00	1 unit	0.458
Separate sensor									
 3RG60 12-3.01	6 ... 30		300	1 NO	–	C	3RG60 12-3AF01	1 unit	0.342
	20 ... 130		300	1 NO	–	C	3RG60 13-3AF01	1 unit	0.381
	6 ... 30		300	1 NC	–	C	3RG60 12-3AE01	1 unit	0.333
	20 ... 130		300	1 NC	–	C	3RG60 13-3AE01	1 unit	0.380
Accessories									
 SONPROG interface unit, AC 100 ... 240 V, DC 24 V						A	3RX4 000	1 unit	0.684

Overview

- Operates as diffuse sensor or reflex sensor
- Adjustable via 2 potentiometers
- Solid-state output:
 - Switching output
- Connection via M12 connector, 3-pin or 4-pin

Selection and ordering data

	Sensing range	Rated operational current	Switching output	Analog output	DT	Order No.	PS	Approx. weight per PU
	cm	mA	pnp					kg
Fixed sensor								
 3RG60 12-3..00	6 ... 30	300	1 NO	–	▶	3RG60 12-3AD00	1 unit	0.239
	20 ... 130	300	1 NO	–	▶	3RG60 13-3AD00	1 unit	0.239
	40 ... 300	300	1 NO	–	▶	3RG60 15-3AD00	1 unit	0.338
	60 ... 600	300	1 NO	–	▶	3RG60 14-3AD00	1 unit	0.420
 3RG60 15-3..00	6 ... 30	300	1 NC	–	▶	3RG60 12-3AC00	1 unit	0.235
	20 ... 130	300	1 NC	–	▶	3RG60 13-3AC00	1 unit	0.241
	40 ... 300	300	1 NC	–	C	3RG60 15-3AC00	1 unit	0.330
	60 ... 600	300	1 NC	–	▶	3RG60 14-3AC00	1 unit	0.424
 3RG60 13-3..00								
 3RG60 14-3..00								
Swivel sensor								
 3RG60 25-3..00	6 ... 30	300	1 NO	–	C	3RG60 22-3AD00	1 unit	0.310
	20 ... 130	300	1 NO	–	C	3RG60 23-3AD00	1 unit	0.313
	40 ... 300	300	1 NO	–	C	3RG60 25-3AD00	1 unit	0.372
	60 ... 600	300	1 NO	–	C	3RG60 24-3AD00	1 unit	0.458
	6 ... 30	300	1 NC	–	C	3RG60 22-3AC00	1 unit	0.316
	20 ... 130	300	1 NC	–	C	3RG60 23-3AC00	1 unit	0.313
	40 ... 300	300	1 NC	–	C	3RG60 25-3AC00	1 unit	0.377
	60 ... 600	300	1 NC	–	C	3RG60 24-3AC00	1 unit	0.458
Separate sensor								
 3RG60 12-3..01	6 ... 30	300	1 NO	–	C	3RG60 12-3AD01	1 unit	0.342
	20 ... 130	300	1 NO	–	C	3RG60 13-3AD01	1 unit	0.375
	6 ... 30	300	1 NC	–	C	3RG60 12-3AC01	1 unit	0.335
	20 ... 130	300	1 NC	–	C	3RG60 13-3AC01	1 unit	0.375

Configuration aids for compact ranges I to III

Dimension drawings

With fixed sensor

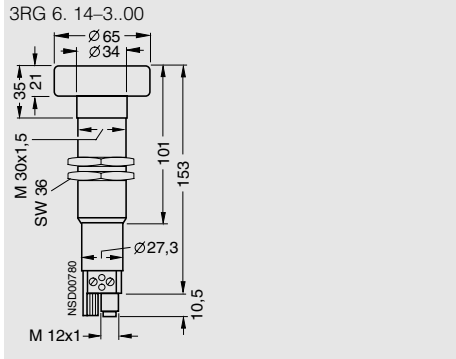
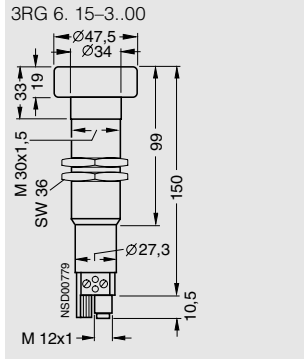
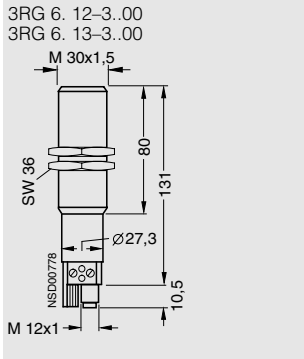

With swivel sensor

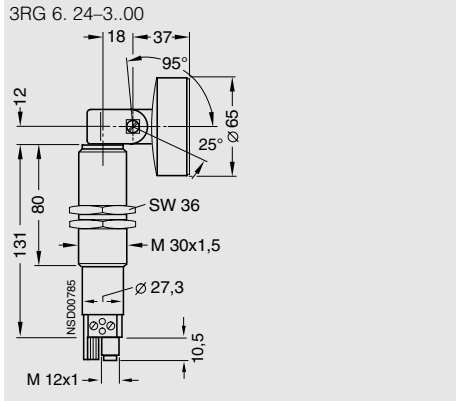
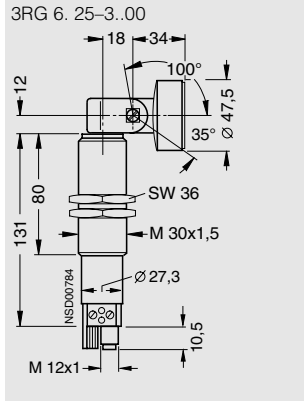
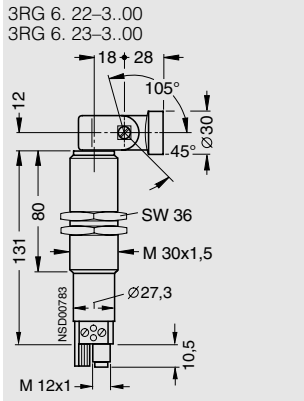

With separate sensor

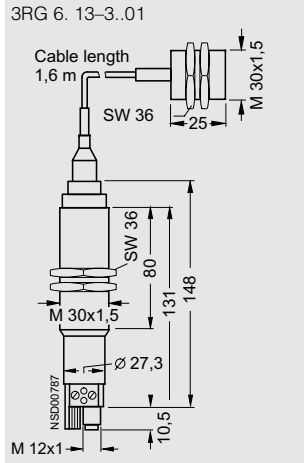
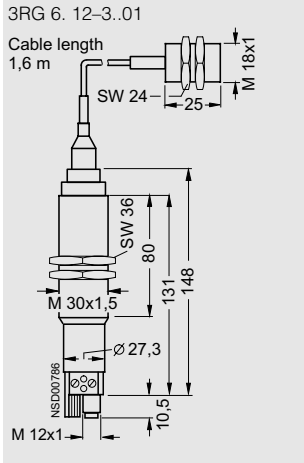

Spherical

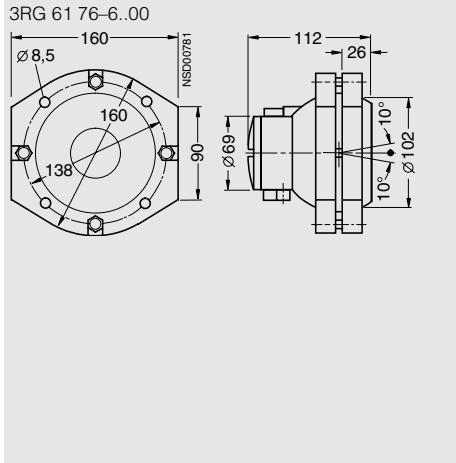

Wherever you find the abbreviation SW in dimension drawings please note that SW means "spanner width" and Sg means "connecting thread".

Circuit diagrams

Compact range I

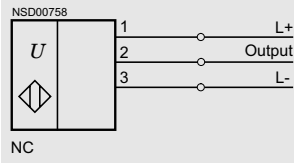
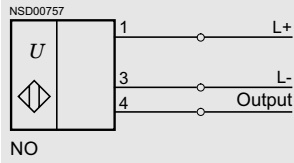

View from rear onto device



Compact range II

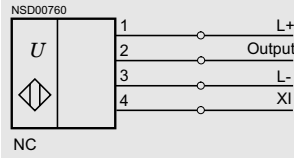
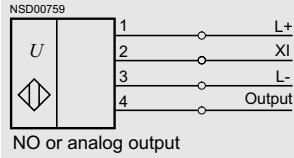

Compact range II with 2 switching outputs

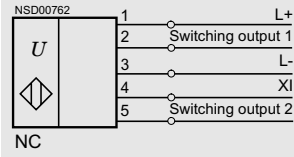
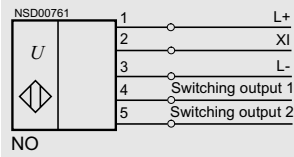

Compact range III

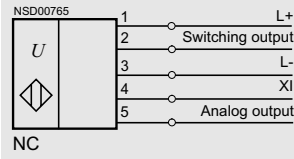
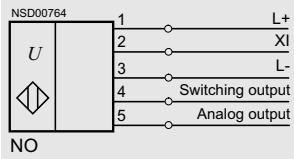

Sonar-BERO

M18 compact range

Overview



M18 form

The Sonar-BEROs of compact range M18 are ready-to-use all-in-one units with a cylindrical enclosure.

- Operates as diffuse sensor, reflex sensor or thru-beam sensor
- Adjustable using 2 potentiometers, with SONPROG interface device or per teach-in
- Foreground and background suppression
- Synchronization capability, multiplex operation
- Temperature compensation
- Solid-state outputs:
 - Switching output
 - Analog output
 - Frequency output, suitable for connection to LOGO!
- Connection via M 12, 4-pin connector

Functions

The devices are suitable for operation as diffuse sensor, reflex sensor and thru-beam sensor. The sensors can be supplied with switching, analog or frequency outputs.

Up to 10 sensors of the M18 compact range can be synchronized with each other via the enable inputs. The devices are also suitable for multiplex mode.

For a detailed description, see compact ranges I to III.

Programming

SONPROG For optimizing to the operating conditions, all sensors of compact range M18 can be programmed using a PC and the SONPROG 3RX4 000 interface device.

The main parameters that can be changed are:

- Lower and upper limit of the operating range
- Differential travel
- Switching function NO or NC
- Switching frequency
- Lower and upper limit of the analog range
- Analog characteristic, rising or falling
- End of close range
- End of sensing range
- Mean value generation
- Multiplex function
- Temperature compensation
- Susceptibility.

The proximity switches can also be ordered with non-standard values. These values must be specified in plain text on ordering.

Design

The devices of compact range M18 are always supplied with permanently installed sensors.

Technical specifications

Type		3RG62 32	3RG62 33
Sensing range	cm	5 ... 30	15 ... 100
Standard target	cm	1 × 1	2 × 2
Differential travel <i>H</i>	mm	10	
Repeat accuracy <i>R</i>	mm	± 1	± 2
Operational voltage (DC)	V	10 ... 30 (including ± 10 % residual ripple, at 10 ... 20 V susceptibility falls by approx. 20 %)	
Rated operational current <i>I_e</i>	mA	150	
No-load supply current <i>I₀</i>	mA	Max. 60	
Ultrasonic frequency	kHz	400	200
Switching frequency <i>f</i>	Hz	5	4
Response time	ms	100	120
Power-up delay <i>t_v</i>	ms	280	280
Switching status display		Yellow LED	
Enclosure material		Brass, nickel-plated; CRASTIN converter cover; epoxy resin converter surface	
Degree of protection		IP67	
Ambient temperature			
• During operation	°C	-25 ... +70	
• During storage	°C	-40 ... +85	

Selection and ordering data

	Sensing range	Rated operational current	Switching output	Analog/frequency output	DT	Order No.	PS	Approx. weight per PU
	cm	mA	pnp					kg
	5 ... 30	150	1 NO	–	▶	3RG62 32-3AB00	1 unit	0.084
	15 ... 100		1 NO	–	▶	3RG62 33-3AB00	1 unit	0.086
	5 ... 30	150	1 NC	–	▶	3RG62 32-3AA00	1 unit	0.085
	15 ... 100		1 NC	–	▶	3RG62 33-3AA00	1 unit	0.088
	5 ... 30	150	–	4 ... 20 mA	▶	3RG62 32-3LS00	1 unit	0.086
	15 ... 100		–	4 ... 20 mA	▶	3RG62 33-3LS00	1 unit	0.087
	5 ... 30	150	–	0 ... 20 mA	C	3RG62 32-3TS00	1 unit	0.088
	15 ... 100		–	0 ... 20 mA	C	3RG62 33-3TS00	1 unit	0.088
5 ... 30	150	–	0 ... 10 V	▶	3RG62 32-3JS00	1 unit	0.087	
15 ... 100		–	0 ... 10 V	▶	3RG62 33-3JS00	1 unit	0.088	
5 ... 30	150	–	250 ... 1500 Hz	C	3RG62 32-3RS00	1 unit	0.088	
15 ... 100		–	150 ... 1000 Hz	C	3RG62 33-3RS00	1 unit	0.091	

Accessories

	SONPROG interface unit AC 100 ... 240 V, DC 24 V	A	3RX4 000	1 unit	0.684
---	--	---	-----------------	--------	-------

Dimension drawings

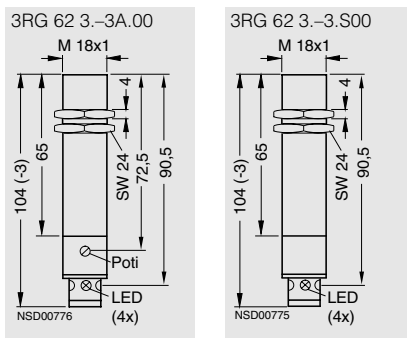

Circuit diagrams

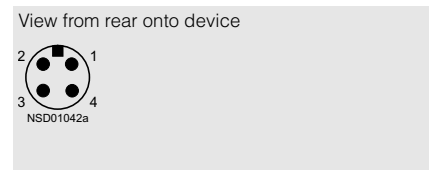
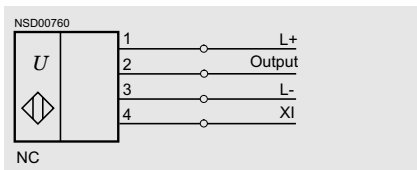
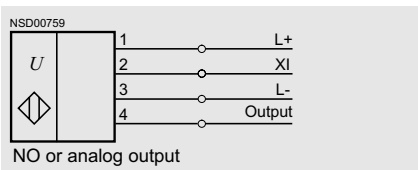

Sonar-BERO

M18 S compact range

Overview



M18 S form

The Sonar-BEROs of compact range M18 S are ready-to-use all-in-one units with a cylindrical enclosure.

- Operates as diffuse sensor or reflex sensor
- Adjustable per teach-in (only with switching output)
- Solid-state outputs:
 - Switching output
 - Frequency output, suitable for connection to LOGO!
- Connection via M12, 4-pin connector

Design

Compact range M18 S can be supplied with an aligned sensor head or an angled sensor head. The small physical size of the sensors makes them ideal for applications where space is limited.

Functions

Available as diffuse sensors and reflex sensors. The sensors can be supplied with switching or frequency outputs. Due to their wide range and a minimized close range, they are suitable for a wide variety of applications.



Programming

The sensors with a switching output can be set via the device terminals by means of a teach-in function. Setting is not possible for sensors with a frequency output. Evaluation can be performed in a PLC or in a LOGO! mini PLC.

Technical specifications

Type		3RG64 .2	3RG64 .1	3RG64 .3
Sensing range	mm	30 ... 200 or 0 ... 200	50 ... 400 or 0 ... 400	100 ... 700 or 0 ... 700
Adjustment range	mm	50 ... 200 or 120 ... 220	60 ... 400 or 155 ... 435	150 ... 700 or 350 ... 750
Standard target	cm	2 x 2	2 x 2	2 x 2
Differential travel <i>H</i>	mm	10 or 2	10 or 2	10 or 3
Repeat accuracy <i>R</i>	mm	± 1 (frequency output ± 2.5)		
Operational voltage (DC)	V	20 ... 30 (including ± 10 % residual ripple)		
Rated operational current <i>I_e</i>	mA	150		
No-load supply current <i>I₀</i>	mA	Max. 20		
Ultrasonic frequency	kHz	400	300	200
Switching frequency <i>f</i>	Hz	10	8	5
Response time	ms	50	100	100
Power-up delay <i>t_v</i>	ms	20	20	20
Switching status display		Yellow LED		
Enclosure material		Brass, nickel-plated; CRAFTIN converter cover; epoxy resin converter surface		
Degree of protection		IP67		
Ambient temperature				
• During operation	°C	-25 ... +70		
• During storage	°C	-40 ... +85		

Selection and ordering data

	Sensing range	Rated operational current	Switching output	Operating mode/frequency output	DT	Order No.	PS	Approx. weight per PU
	cm	mA	pnp					kg
Straight sensor								
	3 ... 20	150	1 NO	Diffuse sensor	A	3RG64 32-3AB00	1 unit	0.063
	5 ... 40		1 NO	Diffuse sensor	A	3RG64 31-3AB00	1 unit	0.055
	10 ... 70		1 NO	Diffuse sensor	A	3RG64 33-3AB00	1 unit	0.059
	0 ... 20	150	1 NO	Reflex sensor	A	3RG64 32-3BB00	1 unit	0.054
	0 ... 40		1 NO	Reflex sensor	C	3RG64 31-3BB00	1 unit	0.054
	0 ... 70		1 NO	Reflex sensor	A	3RG64 33-3BB00	1 unit	0.055
	3 ... 20	150	-	400 ... 1600 Hz 200 ... 800 Hz	C	3RG64 32-3RS00	1 unit	0.054
	5 ... 40		-	240 ... 1600 Hz 60 ... 400 Hz	C	3RG64 31-3RS00	1 unit	0.063
10 ... 70		-	300 ... 1400 Hz 150 ... 700 Hz	C	3RG64 33-3RS00	1 unit	0.055	
Angled sensor								
	3 ... 20	150	1 NO	Diffuse sensor	A	3RG64 22-3AB00	1 unit	0.067
	5 ... 40		1 NO	Diffuse sensor	C	3RG64 21-3AB00	1 unit	0.066
	10 ... 70		1 NO	Diffuse sensor	A	3RG64 23-3AB00	1 unit	0.062
	0 ... 20	150	1 NO	Reflex sensor	C	3RG64 22-3BB00	1 unit	0.057
	0 ... 40		1 NO	Reflex sensor	C	3RG64 21-3BB00	1 unit	0.050
	0 ... 70		1 NO	Reflex sensor	C	3RG64 23-3BB00	1 unit	0.057
	3 ... 20	150	-	400 ... 1600 Hz 200 ... 800 Hz	C	3RG64 22-3RS00	1 unit	0.058
	5 ... 40		-	240 ... 1600 Hz 60 ... 400 Hz	C	3RG64 21-3RS00	1 unit	0.066
10 ... 70		-	300 ... 1400 Hz 150 ... 700 Hz	C	3RG64 23-3RS00	1 unit	0.057	

Dimension drawings

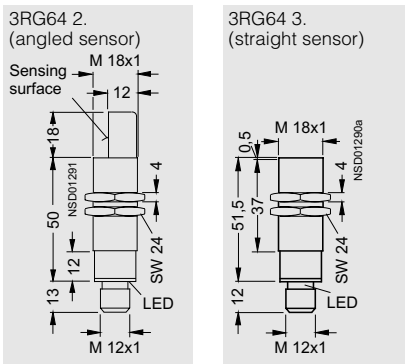

Circuit diagrams

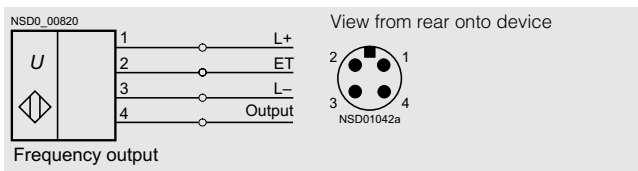

Sonar-BERO

Compact range for pump control

Area of application



M18 and M30 forms (compact range II)

The Sonar-BEROs of designs M30 and M18 with a switching output are suitable for pump controls, e.g. for applications with automated filling or emptying.

In the case of the M30 form, the standard device with a fixed sensor head as well as the devices with separate or swivel sensor heads can be used.

Functions

Automatic emptying

A Sonar-BERO with NO function is used for this purpose.

The fill level rises and approaches the Sonar-BERO:

The switching output is inactive while the level approaches the Sonar-BERO before the maximum fill height is reached. When the maximum level is reached, the Sonar-BERO switches the pump on and automatic emptying is performed until the minimum level is reached (dry running protection). During emptying, the switching output remains active.

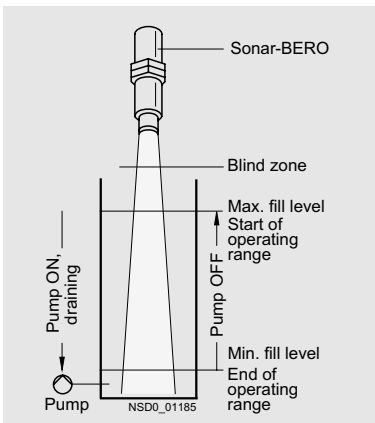

Automatic filling

A Sonar-BERO with NC function is used for this purpose.

The fill level falls and moves away from the Sonar-BERO:

The switching level remains inactive as long as the falling fill level has not reached the minimum fill height. When the minimum level is reached, the Sonar-BERO switches the pump on and automatic filling is performed until the maximum level is reached. During filling, the switching output remains active.

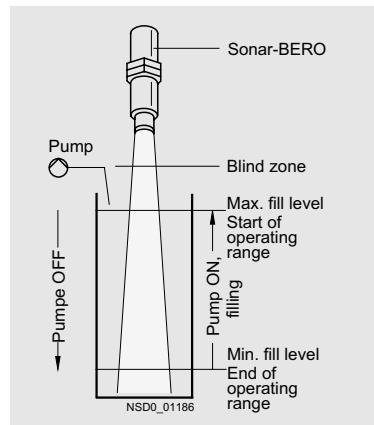

Programming

The devices can be switched to fill level mode by means of the SONPROG interface unit.

The existing potentiometers, SONPROG software or teach-in keys of the SONPROG interface device can be used to set the lower and upper limits of the operating range.

With the M30 form, both the lower and upper limit of the operating range can be set using the potentiometers, but only the lower limit can be set with the M18 form; the start is fixed in the latter case. It is important to set a mean value. Mean value generation over 100 measured values is recommended as standard.

The required parameters can also be set at the factory. For this purpose, the Order No. must be supplemented by "-Z". Furthermore, "**Z = fill level software**" and the required parameters should be specified in plain text:

- NO (automatic emptying) or NC (automatic filling)
- Fill level limits adjustable via potentiometers or permanently programmed, then:
 - Lower limit of operating range (maximum fill level)
 - Upper limit of operating range (minimum fill level)
- Mean value.

Overview

The Sonar-BEROs of K08 compact form are ready-to-use all-in-one units with a rectangular metal enclosure.

- 3 versions with different operating modes:
 - Diffuse sensor with background suppression
 - Reflex sensor
 - Thru-beam sensor
- Diffuse sensor and reflex sensor:

- Up to 6 devices can be synchronized
- Adjustment per teach-in

- Solid-state outputs:
 - 1 pnp and 1 npn switching output
 - NO/NC contact selectable, or NO contact
- Connection via M12 connector, 5-pin, rotatable by 90°

Technical specifications

Type		3RG64 51-3CC00	3RG64 51-3DC00	3RG64 51-3SB00
Operating mode		Diffuse sensor	Reflex sensor	Thru-beam sensor
Sensing range	mm	50 ... 400	0 ... 400	0 ... 800
Adjustment range	mm	60 ... 400	60 ... 400	0 ... 800
Standard target	cm	2 × 2	2 × 2	2 × 2
Differential travel <i>H</i>	mm	10	2	–
Repeat accuracy <i>R</i>	mm	± 1	± 1	–
Operational voltage (DC)	V	20 ... 30 (including ± 10 % residual ripple)		
Rated operational current <i>I_e</i>	mA	150		
No-load supply current <i>I₀</i>	mA	Max. 25		
Ultrasonic frequency	kHz	300	300	300
Switching frequency <i>f</i>	Hz	8	8	250
Response time	ms	100	100	100
Power-up delay <i>t_v</i>	ms	250	250	250
Displays		Yellow LED Green LED		
• Switching status				
• Operating voltage range				
Enclosure material		Metal		
Degree of protection		IP67		
Ambient temperature				
• During operation	°C	–25 ... +70		
• During storage	°C	–40 ... +85		

Selection and ordering data

	Sensing range	Rated operational current	Switching output	Operating mode	DT	Order No.	PS	Approx. weight per PU
	mm	mA	pnp + npn					kg
	50 ... 400	150	1 selectable NO/NC contact each	Diffuse sensor	A	3RG64 51-3CC00	1 unit	0.080
	0 ... 400	150	1 selectable NO/NC contact each	Reflex sensor	C	3RG64 51-3DC00	1 unit	0.072
	–	–	–	Thru-beam sensor emitter	C	3RG64 51-3NN00	1 unit	0.072
	0 ... 800	150	1 NO contact each	Thru-beam sensor receiver	C	3RG64 51-3SB00	1 unit	0.072

Dimension drawing

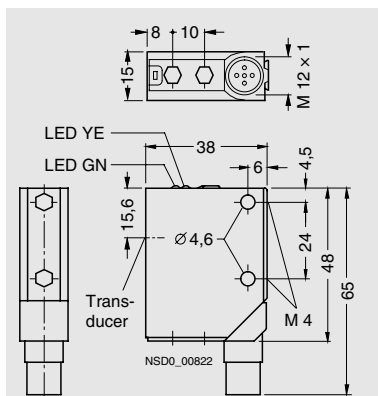

Circuit diagrams

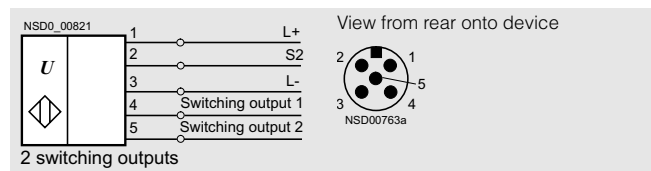

Compact range 0

Overview



Compact range 0 with separate and fixed sensors

The Sonar-BEROs of compact range 0 are all-in-one units with a rectangular enclosure, and are ready for connection. They are available with two sensing ranges.

- Operates as diffuse sensor
- Adjustable via potentiometer
- Can be synchronized
- Temperature compensation
- Solid-state outputs:
 - Switching output
 - Analog output
- Connection via M12 connector, Type F

Design

The devices of compact range 0 are supplied in the standard version with permanently installed sensors.

The devices of compact series 0 can also be supplied with separate sensors. Due to its small dimensions, the sensor is especially suitable in confined spaces.

The ultrasonic sensor is installed in a cylindrical enclosure separated from the other electronics. In devices of type 3RG63 42, the sensor is installed in an M18 shell and in devices of type 3RG63 43 it is installed in an M30 shell with a length of 25 mm in both cases.

Two nuts are supplied for fixing. The connecting lead of approximately 1.6 m in length is cast onto the sensor. The connection to the evaluation electronics located in the enclosure of compact range 0 is established via the preassembled coaxial cable plug. The mating socket is installed on the end face of the enclosure.

Functions

Compact range 0 is designed for simple applications. The devices are only suitable for operation as diffuse sensors.



The sensors can be supplied with analog outputs. The end of operating range or analog range can be set using a potentiometer.

Up to 6 devices can be synchronized with each other.

Technical specifications

Type		3RG63 42	3RG63 43
Sensing range	cm	6 ... 30	20 ... 100
Standard target	cm	1 × 1	2 × 2
Differential travel <i>H</i>	mm	5	10
Repeat accuracy <i>R</i>	mm	± 0.45	± 1.5
Operational voltage (DC)	V	10 ... 35 (including ± 10 % residual ripple, at 10 ... 18 V susceptibility falls by approx. 30 %)	
Rated operational current <i>I_e</i>	mA	100	
No-load supply current <i>I₀</i>	mA	Max. 35	
Ultrasonic frequency	kHz	400	200
Switching frequency <i>f</i>	Hz	8	5
Response time	ms	70	90
Power-up delay <i>t_v</i>	ms	7	7
Switching status display		Yellow LED	
Enclosure material		CRASTIN; epoxy resin converter surface	
Degree of protection		IP65; IP68 with separate sensor	
Ambient temperature			
• During operation	°C	0 ... +55	
• During storage	°C	-40 ... +85	

Selection and ordering data

	Sensing range	Rated operational current	Switching output	Analog output	DT	Order No.	PS	Approx. weight per PU
	cm	mA	pnp					kg
Fixed sensor								
	6 ... 30	100	1 NO	–	▶	3RG63 42–3AB00	1 unit	0.176
	20 ... 100	100	1 NO	–	▶	3RG63 43–3AB00	1 unit	0.173
	6 ... 30	100	1 NC	–	C	3RG63 42–3AA00	1 unit	0.176
	20 ... 100	100	1 NC	–	C	3RG63 43–3AA00	1 unit	0.176
	6 ... 30	100	–	0 ... 10 V	▶	3RG63 42–3JK00	1 unit	0.173
	20 ... 100	100	–	0 ... 10 V	▶	3RG63 43–3JK00	1 unit	0.176
Separate sensor								
	6 ... 30	100	1 NO	–	▶	3RG63 42–3AB01	1 unit	0.236
	20 ... 100	100	1 NO	–	▶	3RG63 43–3AB01	1 unit	0.282
	6 ... 30	100	1 NC	–	C	3RG63 42–3AA01	1 unit	0.238
	20 ... 100	100	1 NC	–	C	3RG63 43–3AA01	1 unit	0.295
	6 ... 30	100	–	0 ... 10 V	A	3RG63 42–3JK01	1 unit	0.240
	20 ... 100	100	–	0 ... 10 V	C	3RG63 43–3JK01	1 unit	0.285

3

Dimension drawings

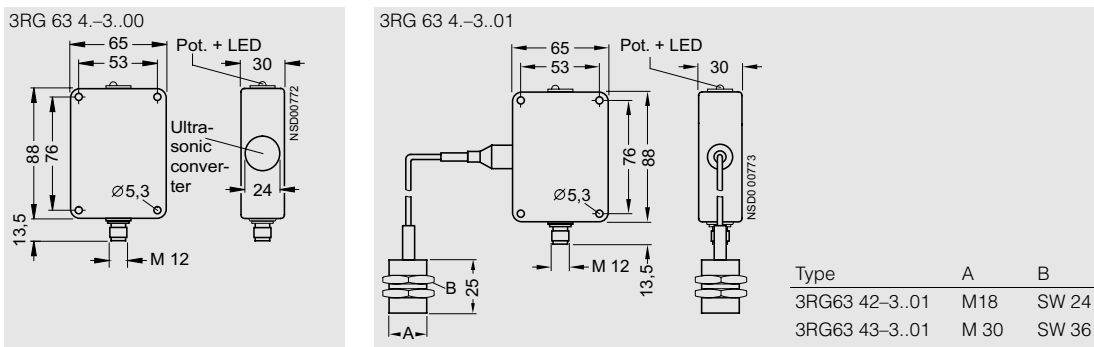

Circuit diagrams

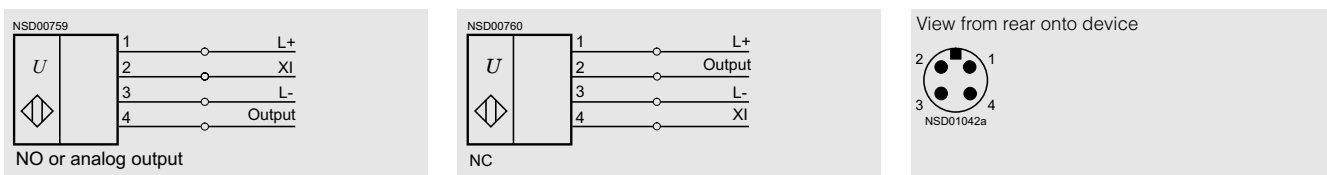

Sonar-BERO

3SG16 compact form

Overview



Compact form 3SG16

The Sonar-BERO in compact design for DC is a complete, factory-assembled unit, ready for connection. It cannot be combined with devices from the compact ranges and modular range.

- Operates as diffuse sensor or reflex sensor
- Foreground and background suppression
- Adjustable using plug-in jumpers
- Solid-state outputs:
 - 2 switching outputs
- Terminal compartment with screw terminals

Design

All components are located into a single box-shaped enclosure. The ultrasonic converter and the terminal compartment are arranged on the same enclosure level.

The electrical connections are made via screw terminals in the terminal compartment; cable entry is through an M20 cable gland.

Aligning unit

To make it easier to align the Sonar-BERO with the object to be detected, a 3SX6 287 aligning unit is available.

This unit allows swiveling about a horizontal and a vertical axis with an angle of rotation in each case of up to 30°.

Functions

Range definition and adjustability

The Sonar-BERO outputs a signal while an object is located in the set operating range or inhibit range within an aperture angle of approximately 5° (see Fig.).

The sensing range between 0.2 and 1 m is subdivided into 8 equal operating ranges of 0.1 m. Each operating range B1 to B8 can be selected using a connector in the terminal compartment.

The Sonar-BERO signals with one output and one LED in each case whether objects are located in the set operating range or in the so-called inhibit range that precedes it.

With the help of the supplied programming plug, two to eight of the separate operating ranges (B1 to B8) can be combined to form an extended operating range.

One programming plug is required for each operating range which can in each case only be connected to the immediately adjacent range. The plug is fitted to a pin connector in the terminal compartment of the device. The possible pin assignments are shown in the cover of the terminal compartment.

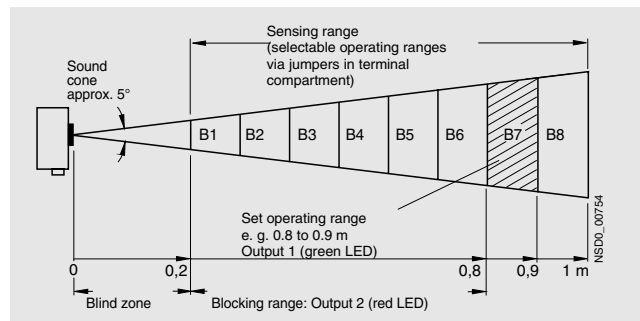

Operating modes

Standard operating mode: Diffuse sensor

The Sonar-BERO switches when an object enters the sound cone from any direction, output 14 (NO) outputs a 1-signal if the object is located within a set operating range (B1 to B8). Output 24 (SX) outputs a 1-signal if the object is in the inhibit range. Objects in the blind zone do not cause a utilizable signal change on outputs 14 and 24.

Reflex sensor

If a reflector is permanently fixed within a set operating range, the ultrasonic beam will be interrupted by all objects in the inhibit range even those that absorb sound.

In this case, output 14 (NO) changes to the 0-signal. In the case of reflective objects in the inhibit range, output 24 (SX) changes to the 1-signal at the same time.

Series and parallel connection

Series connection of the Sonar-BERO (terminal 2 or 4) is possible. The voltage drops must, however, be taken into account.

Parallel connection of the outputs is also possible. If the Sonar-BEROs that are in parallel are connected to different power supply units, the outputs must be decoupled via diodes (diodes for 300 mA, 150 to 300 V control voltage, recommended diode type, e.g. 1N4004).

Technical specifications

Sensing range	cm	20 ... 100
Standard target	cm	2 × 2
Differential travel <i>H</i>	mm	10
Repeat accuracy <i>R</i>	mm	± 2
Operational voltage (DC)	V	10 ... 35 (including ± 10 % residual ripple, at 10 ... 18 V susceptibility falls by approx. 30 %)
No-load supply current <i>I</i>₀	mA	< 60
Switching output		
• Rated operational current <i>I</i> _e	mA	150
• Voltage drop	V	2
• Residual current	mA	0.01
Ultrasonic frequency	kHz	200
Switching frequency <i>f</i>	Hz	4
Response time	ms	120
Power-up delay <i>t</i>_v	ms	280
Switching status display		Yellow LED
Enclosure material		CRASTIN; epoxy resin converter surface
Degree of protection		IP65
Ambient temperature		
• During operation	°C	-25 ... 70
• During storage	°C	-40 ... 85

Selection and ordering data

Sensing range	Rated operational current	Switching output	Connection	DT	Order No.	PS	Approx. weight per PU
cm	mA	pnp					kg
20 ... 100	150	2 NO	Terminal compartment	▶	3SG16 67-1BJ87	1 unit	0.519

Accessories

Aligning unit	A	3SX6 287	1 unit	0.310
----------------------	---	-----------------	--------	-------

Dimension drawing

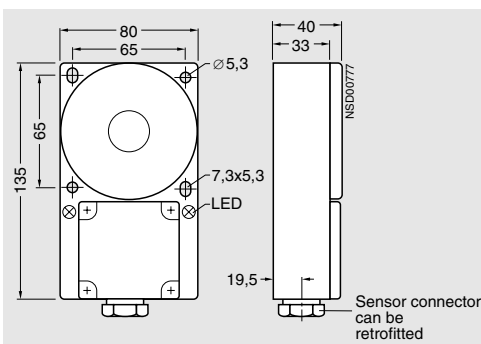

Circuit diagram

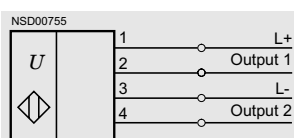

Sonar-BERO

K65 compact form

Area of application

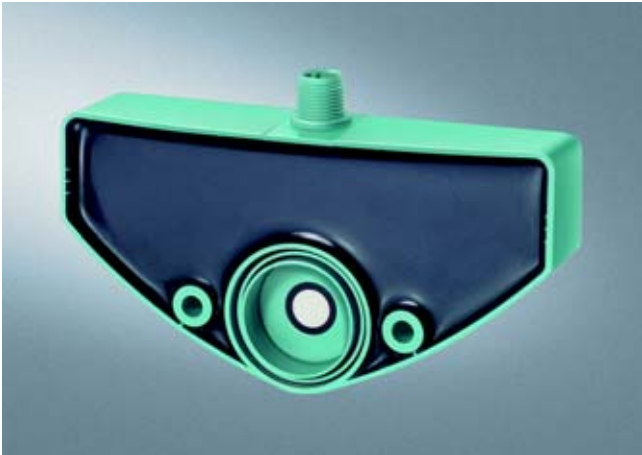

Compact form K65

The Sonar-BEROs of the K65 compact design are ready-to-use complete self-contained units. They operate with a DC supply. Their enclosure design and function makes them ideal for level applications in small containers.

The devices feature two switching outputs (S_{\min} and S_{\max}) to which different distances can be assigned. This allows, for example, the minimum and maximum fill level in a tank to be evaluated. The values are set using the SONPROG interface device or by means of automatic alignment (teach-in function).

Design

All components are located in a box-shaped enclosure with rounded edges. The ultrasonic converter is mounted in the enclosure – slightly recessed – in the enclosure. The integrated encircling sealing ring allows the Sonar-BERO to be used as a plug with integrated level measuring.

The tank opening must have a minimum diameter of 26 mm. It can be fixed to the tank by means of two M5 screws.

The electric connection is made using a 5-pin connector with M12 thread.

Functions

Sensors with switching or analog output

Within the sensing range, the fill level of a container is detected. If the fill level reaches one of the two switching thresholds (S_{\min} , S_{\max}), the corresponding output is set. On emptying or filling, the switching outputs remain set in accordance with the differential travel (H_{\min} , H_{\max}). This is signaled by the corresponding LED. If the level is located between the two operating ranges, both outputs are reset (see "Definition of the ranges").

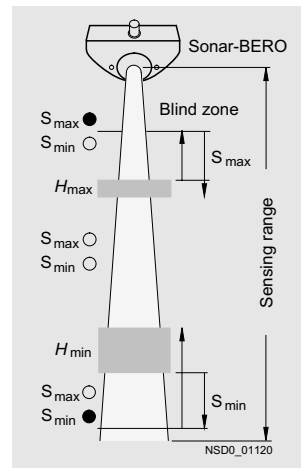

Definition of the ranges

Blind zone

Objects at close range cause fault signals, so the user must install the sensor such that the fill level cannot enter close range.

Programming

SONPROG For optimizing to the operating conditions, all sensors of compact form K65 can be programmed using a PC and the SONPROG 3RX4 000 interface device.

The main parameters that can be changed are:

- Lower and upper limit of the operating range
- Differential travel
- Switching function NO or NC
- Switching frequency
- Lower and upper limit of the analog range
- Analog characteristic, rising or falling
- End of close range
- End of sensing range
- Mean value generation
- Multiplex function
- Temperature compensation
- Susceptibility.

The proximity switches can also be ordered with non-standard values. These values must be specified in plain text on ordering.

Technical specifications

Type		3RG62 52	3RG62 53	3RG62 55
Sensing range	cm	6 ... 50	20 ... 150	25 ... 250
Standard target	cm	1 × 1	2 × 2	5 × 5
Switching threshold				
• S_{max}	cm	8	25	35
• S_{min}	cm	45	140	230
Differential travel H				
• H_{max} (adjustable)	cm	2	5	10
• H_{min} (adjustable)	cm	10	10	20
Operational voltage (DC)	V	20 ... 30 (including ± 10 % residual ripple)		
No-load supply current I_0	mA	Max. 60		
Switching output				
• Rated operational current I_e	mA	150		
• Voltage drop	V	2		
• Switching element function S_{max}		NO		
• Switching element function S_{min}		NO/NC programmable		
Ultrasonic frequency	kHz	400	200	100
Measuring time	ms	20	25	50
Displays		2 yellow LEDs		
• Switching status		Green LED		
• Operating voltage range				
Enclosure material		CRASTIN; epoxy resin converter surface		
Degree of protection		IP65		
Ambient temperature				
• During operation		-25 ... 70		
• During storage		-40 ... 85		

Selection and ordering data

	Sensing range	Rated operational current	Switching output	Analog/ frequency output	Connection	DT	Order No.	PS	Approx. weight per PU
	cm	mA	pnp						kg
	6 ... 50	150	2 NO	–	M 12 connector	C	3RG62 52-3AH00	1 unit	0.257
	20 ... 150	150	2 NO	–	M 12 connector	C	3RG62 53-3AH00	1 unit	0.253
	25 ... 250	150	2 NO	–	M 12 connector	C	3RG62 55-3AH00	1 unit	0.259
	6 ... 50	300	1 NO	4 ... 20 mA	M 12 connector	C	3RG62 52-3BF00	1 unit	0.257
	20 ... 150	300	1 NO	4 ... 20 mA	M 12 connector	C	3RG62 53-3BF00	1 unit	0.253
	25 ... 250	300	1 NO	4 ... 20 mA	M 12 connector	C	3RG62 55-3BF00	1 unit	0.259
	6 ... 50	300	1 NO	0 ... 20 mA	M 12 connector	C	3RG62 52-3CF00	1 unit	0.257
	20 ... 150	300	1 NO	0 ... 20 mA	M 12 connector	C	3RG62 53-3CF00	1 unit	0.253
	25 ... 250	300	1 NO	0 ... 20 mA	M 12 connector	C	3RG62 55-3CF00	1 unit	0.259
	6 ... 50	300	1 NO	0 ... 10 V	M 12 connector	C	3RG62 52-3GF00	1 unit	0.257
	20 ... 150	300	1 NO	0 ... 10 V	M 12 connector	C	3RG62 53-3GF00	1 unit	0.253
	25 ... 250	300	1 NO	0 ... 10 V	M 12 connector	C	3RG62 55-3GF00	1 unit	0.259
	6 ... 50	300	1 NO	20 ... 150 Hz	M 12 connector	C	3RG62 52-3RS00	1 unit	0.257
	20 ... 150	300	1 NO	20 ... 130 Hz	M 12 connector	C	3RG62 53-3RS00	1 unit	0.253
	25 ... 250	300	1 NO	30 ... 150 Hz	M 12 connector	C	3RG62 55-3RS00	1 unit	0.259

Accessories



SONPROG interface unit,
AC 100 ... 240 V, DC 24 V

A **3RX4 000** 1 unit 0.684

Sonar-BERO

K65 compact form

Dimension drawing

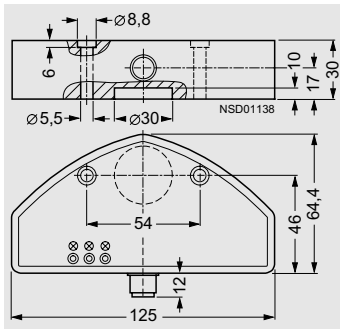

Circuit diagrams

Sensors with switching output

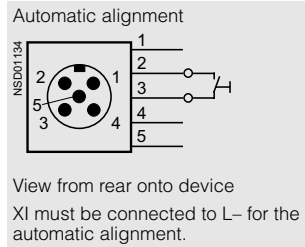
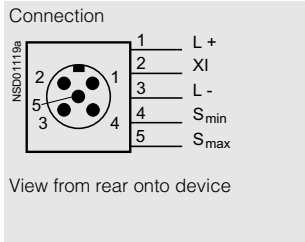

Overview



Sonar thru-beam sensor

The sonar thru-beam sensor comprises an ultrasonic emitter and a receiver. The emitter and receiver circuits are installed in separate box-shaped enclosures of molded plastic.

- Operation as thru-beam sensor
- 3 measurement ranges can be set
- Solid-state output:
 - Switching output
- Connection
 - With 3 m cable
 - With M8 connector, 4-pole
 - With M12 connector, 4-pole

Functions

Thru-beam sensor mode

The emitter of the sonar thru-beam sensor emits a narrowly focused continuous tone in the direction of the receiver.

The receiver located opposite evaluates this ultrasonic signal. Interruption of the tone by an object will cause the output signal to change.

Adjustment of sensitivity

The sensitivity can be adjusted at the receiver module at terminal 2 (NO version) or 4 (NC version).

XI	Switching frequency	Emitter/receiver distance
	Hz	cm
Not connected	100	< 150
L-	150	< 80
L+	200	< 40

Object detection

The minimum size of detectable objects depends on the distance between emitter and receiver. If the distance is less than 40 cm, objects 2 cm or larger will be detected. The gap with between two objects must be at least 3 mm.

If the distance is shorter, gaps of < 1 mm can even be detected. At maximum distance, objects greater than 4 cm in size can be detected. In this case the gaps between the objects must be > 1 cm.

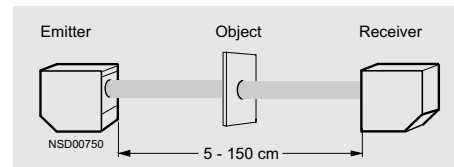

Arrangement

Sonar-BERO

Thru-beam sensor

Technical specifications

Type	3RG62 43-.P (receiver)		3RG62 43-.N (emitter)	
Sensing range	cm	–	5 ... 150	
Standard target				
• Up to 40 cm	cm	2 × 2		
• Over 40 cm	cm	1 × 1		
Operational voltage (DC)	V	20 ... 30 (including ± 10 % residual ripple)		
Rated operational current I_e	mA	100		
No-load supply current I_0	mA	< 20	< 30	
Ultrasonic frequency	kHz	–	200	
Switching frequency f				
• Up to 40 cm	Hz	200		
• Up to 80 cm	Hz	150		
• Up to 150 cm	Hz	100		
Response time				
• Up to 40 cm	ms	2		
• Up to 80 cm	ms	1.5		
• Up to 150 cm	ms	1		
Power-up delay t_v	ms	< 40		
Status indication		Green LED		
Enclosure material		CRASTIN; epoxy resin converter surface		
Degree of protection		IP65		
Ambient temperature				
• During operation	°C	0 ... 70		
• During storage	°C	–25 ... 85		

Selection and ordering data

	Sensing range	Rated operational current	Switching output	Connection	DT	Order No.	PS	Approx. weight per PU
	cm	mA	pnp					kg
	5 ... 150	100	1 NO	Cable, 3 m	A	3RG62 43-0PB00	1 unit	0.130
	5 ... 150	100	1 NC	Cable, 3 m	C	3RG62 43-0PA00	1 unit	0.135
	5 ... 150	–	Emitter	Cable, 3 m	A	3RG62 43-0NN00	1 unit	0.130
	5 ... 150	100	1 NO	M 8 connector	C	3RG62 43-7PB00	1 unit	0.190
	5 ... 150	100	1 NC	M 8 connector	C	3RG62 43-7PA00	1 unit	0.056
	5 ... 150	–	Emitter	M 8 connector	C	3RG62 43-7NN00	1 unit	0.050
	5 ... 150	100	1 NO	M 12 connector	▶	3RG62 43-3PB00	1 unit	0.056
	5 ... 150	100	1 NC	M 12 connector	C	3RG62 43-3PA00	1 unit	0.059
	5 ... 150	–	Emitter	M 12 connector	▶	3RG62 43-3NN00	1 unit	0.055

Dimension drawings

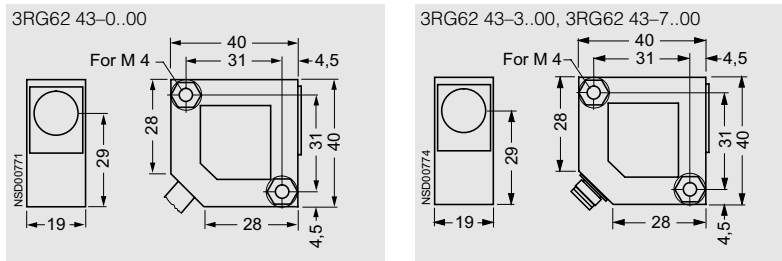

Circuit diagrams

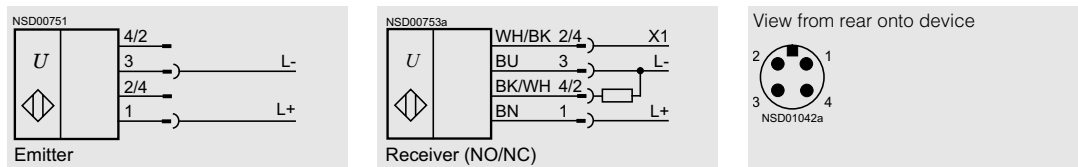

Double-layer sheet monitoring

Overview



Double-layer sheet monitoring with separate sensors

The 3RX2 210 Sonar-BERO for double-layer sheet monitoring comprises one signal evaluator and two Sonar sensors (emitter and receiver).

- Reliable detection of multiple layers of paper, plastic sheets or metal foil
- Measuring range from 20 g paper to 1100 g card
- Manual or automatic offset
- Sonar sensors in M18 enclosure
- Short-circuit proof electronic outputs (pnp)
- Connection via M12 connector.

Design

The emitter and receiver sensors are of the same type and must be mounted at an angle of $30^\circ (\pm 10^\circ)$ or 5° to the vertical. The setting is made using the internal S2 switch. If the system is operated at an inclination angle of 5° to 20° , the S2 switch (operating mode) must be set to position "1".

The object to be detected must be located approximately 5 to 15 mm above the emitter. A wider mounting angle increases the flutter range, e. g. at an angle of 40° , fluttering within 60 % of the measuring range is permitted.

The spacing between the emitter and receiver must be at least 20 mm and can be up to 60 mm. Precise alignment is essential ($\pm 1^\circ$). The operating range is reduced if they are not aligned along the axis.

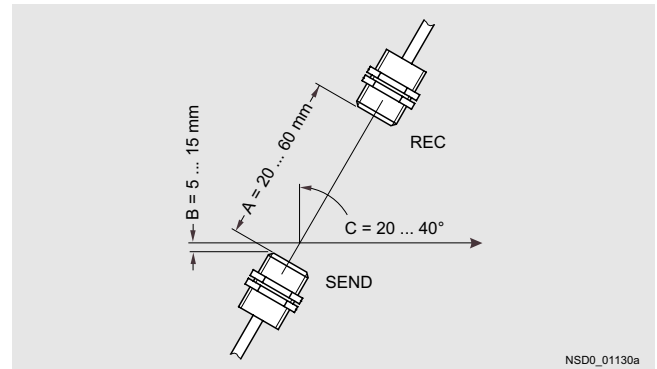

Mounting of the sensors

Functions

These devices are used mainly for monitoring sheets of paper as well as plastic and metal film. Each layer is compared to the stored reference value and indicated as a single or double layer accordingly.

The 3RX2 210 signal evaluator continuously signals the situation between the sonar sensors at the two outputs A1 and A2. Output A1 "Single layer" remains active as long as only one layer is located between the sensors. Output A2 "Double layer" is activated as soon as two or more layers are detected between the sensors. Two LEDs also indicate the status of the outputs. The yellow LED A1 indicates a single layer and the red LED A2 indicates a double layer.

Programming

The signal evaluator can be set to two different modes.

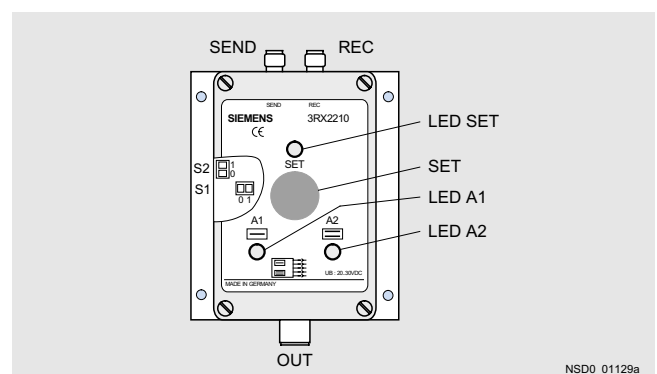

User interface

Sonar-BERO

Double-layer sheet monitoring

Manual setting

Switch S1 (setting) is in position "1".

The sensor is set up for the material to be sensed either by pressing the "SET" button on the top of the device or by applying a control command to the "SET" input of the M12 connector (pin 5). The value obtained remains stored until the setting procedure is repeated. The sensor is set by placing a single layer between the sonar sensors and activating the "SET" command.

The 3RX2 210 requires max. 100 ms for the setting; i.e. the "SET" key must be pressed for this time, or a "1" signal (> 6 V) must be

present at pin 5. The green LED "SET" flashes during the setting. It lights up permanently following successful setting.

Automatic setting

Switch S1 (setting) is in position "0" (factory setting).

Setting can be performed as described above or automatically when a layer is fed in and the supply voltage is applied if a layer lies between the sensors at this moment.

Automatic setting is performed when a layer is fed in following an interval of 2 s during which a layer was not detected between the sonar sensors.

Technical specifications

Sensing range	mm	20 ... 60
Material strength (paper, cardboard)	G	20 ... 1100
Operational voltage (DC)	V	18 ... 36 (including ± 10 % residual ripple)
No-load supply current I_0	mA	< 75
Switching output		
• Rated operational current I_e	mA	200
• Voltage drop at 200 mA	V	< 3
Ultrasonic frequency	kHz	200
Switching frequency f	Hz	100
Response time	ms	5
Switching status display	Red and yellow LEDs	
Enclosure material		
• Evaluation unit	Metal	
• Sensor	Brass, nickel-plated; epoxy resin converter surface	
Degree of protection	IP65	
Ambient temperature		
• During operation	°C	0 ... 65
• During storage	°C	-40 ... 85

Selection and ordering data

Sensing range	Rated operational current	Switching output	Connection	DT	Order No.	PS	Approx. weight per PU
cm	mA	npn					kg
2 ... 6	200	2 NO	M 12 connector	C	3RX2 210	1 unit	0.500

Dimension drawings

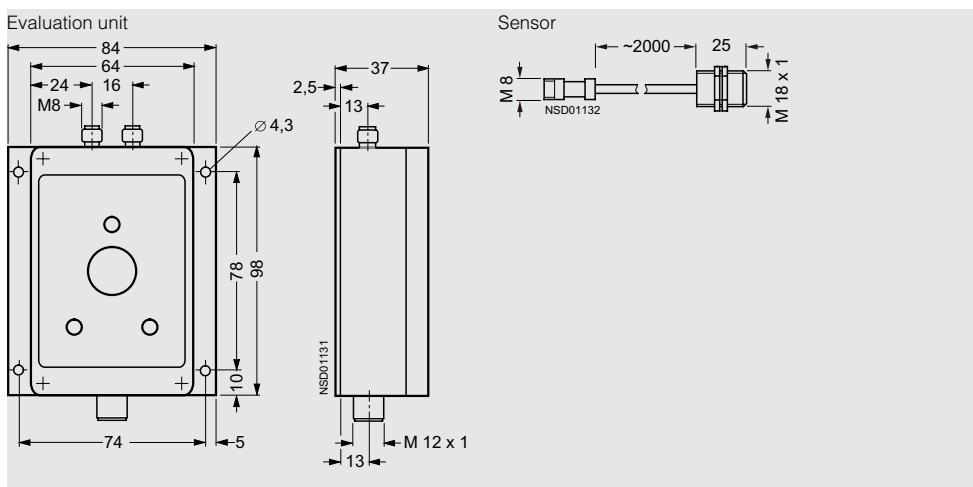

Overview



PC with SONPROG interface device and Sonar-BERO

SONPROG

Using the SONPROG 3RX4 000 PC interface device and the relevant software, the following Sonar-BEROs can be individually adapted to the respective application requirements:

- Compact ranges II and III
- M18 compact range
- K65 compact form.

Scope of supply

- PC interface
- Plug-in power supply
- Connecting leads to the PC and Sonar-BERO
- SONPROG software for Windows.

Functions

The SONPROG 3RX4 000 programming device allows the user to program several Sonar-BEROs simultaneously. The lower and upper limit of the operating range can be saved at the click of a button for copying to other Sonar-BEROs.

For each Sonar-BERO, the following parameters can be set:

- Lower and upper limit of the operating range
- Differential travel
- Switching function NO or NC
- Switching frequency
- Lower and upper limit of the analog characteristic
- Analog characteristic, rising or falling
- End of close range
- End of sensing range
- Mean value generation
- Attenuation.

The function can also be set for the device:

- Multiplex function
- Temperature compensation
- Function as diffuse or reflex sensor
- Fill level mode (see "Compact range for pump control").

The programmed values are saved in the Sonar-BERO and are retained even without interface or after the supply voltage has been disconnected.

The programmed values can be printed out and recorded. They will then be immediately available, for example, for series applications or for replacement of the Sonar-BERO.

Parameters

Operating range

The commands "Lower limit of operating range" and "Upper limit of operating range" are used to define a window within the sensing range of the Sonar-BERO.

If an object enters the operating range, the switching output is active (with NO contact). If an object is outside the operating range, the switching output is not active.

In the case of Sonar-BEROs of compact range II with two switching outputs, the second switching output is active when an object is located between the blind zone and the operating range.

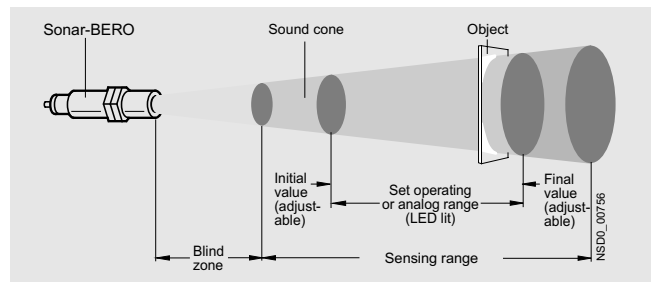

Sound cone

Differential travel

The differential travel can be adjusted to move the switch-on point and the switch-off point at the limits of the operating range away from each other. This prevents output flutter and level control tasks can be solved elegantly.

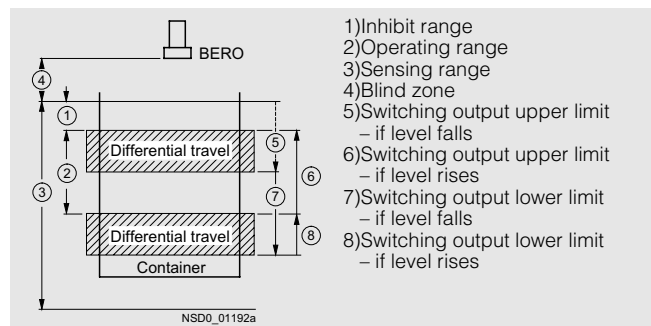

Example: Fill level monitoring with adjustable differential travel

Switching output function

The function of the switching output that was set at the factory can be changed, e.g. from NO to NC.

The pin assignments are not changed. This means that the switching output remains at pin 4 even if a device is changed from NO to NC function.

Switching frequency

The Sonar-BERO can be switched over from standard switching frequency (in accordance with the technical specifications) and rapid switching frequency (3 times the standard value).



Note: A Sonar-BERO with a rapid switching frequency is more sensitive to disturbance.

Sonar-BERO

Accessories

SONPROG PC interface

Analog distance measurement

BEROs with an analog output can detect the distance to an object. This distance is converted to an analog signal that is proportional to it (0 to 10 V, 0 to 20 mA or 4 to 20 mA). The resolution of the analog output is at least mm within the preset limits.

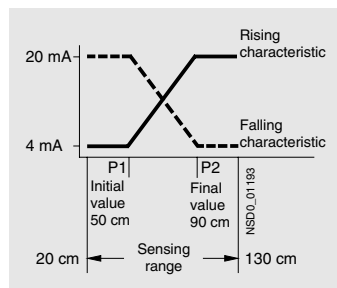

Example

Blind zone

A value must not be set for the blind zone that is less than the minimum value. This is the time that the Sonar-BERO requires to switch over from send to receive mode.

The blind zone can be moved away from the Sonar-BERO (i.e. increased) to permit interfering objects in the foreground to be ignored. The interfering echo resulting from such an object is suppressed by extending the blind zone, and detection of the desired object is possible again. The range of the Sonar-BERO can be reduced in this case because part of the echo from the object to be detected is suppressed. However, objects are still not permitted within the original blind zone.

It is important to ensure with this setting the object does not reflect ultrasound so well that double or triple echoes arise that give the impression of a more distant object. (a fault of this kind cannot occur during normal operation because only the first echo is accepted as valid).

Sensing range

Reducing the sensing range can enhance the resolution of the Sonar-BERO. With large sensing ranges, it is not possible to adjust some values in steps of one millimeter. The minimum resolution of a Sonar-BERO is 1 mm.

Mean value generation

Unfortunate reflective conditions or moving surfaces (e.g. in the case of moving liquids and bulk material on conveyors) can cause the measured values to change continuously which results in constant switching. The Sonar-BERO allows a mean value to be generated from up to 255 measurements.

Failed signals (when no object is in the sensing range) are ignored on mean-value generation. After each measurement, a mean value is generated immediately from the new measured value and the stored number of old values. The response time of the Sonar-BERO is, therefore, not extended. A delay only occurs at the end of a measurement if the object is removed from the sensing range. This delay corresponds to the measurement cycle time multiplied by the saved number of mean values.

Sensitivity (see sound cones)

The susceptibility of the receive amplifier is reduced here. Weakly reflecting objects at the edge of the sound cone are suppressed. It is also possible to reduce the size of the sound cone here electronically. The permitted values are 0 (maximum sensitivity) to 7 (minimum sensitivity).

Teach-in

All Sonar-BEROs of compact ranges II, III and M18 can now be adjusted to the limits of the operating range by means of a teach-in function. For this purpose, the Order No. must be supplemented by **"-ODT0"**.

Teach-in is activated via a Low signal (0 V) on terminal XI. This can be applied via a key or jumper; teach-in can also be made via an electronic signal (e.g. PLC output). The signal is non-time-critical; the duration must be longer than 150 ms.

Various adjustments can be implemented using the SONPROG V2.x software. The user can select which value is to be taught. In compact ranges II and III, the selection can also be made via the potentiometer (set using SONPROG)

The following adjustments can be implemented using the SONPROG V2.x software:

- Teach-in mode:
 - Enabled
 - Disabled
- Teach-in mode (adjustable via potentiometer) for:
 - Start of range
 - End of range

M18 compact range

For sensors with a switching output, the switching limit is taught that was specified in the SONPROG programming (setting as supplied: maximum switching limit).

For sensors with an analog output, the analog limit is taught that was specified in the SONPROG programming (setting as supplied: maximum analog value)

Compact ranges II and III

For the compact range II, the switching limits are taught; for the compact range III, the analog limits are taught.

Teach-in procedure

- The LED flashes during teach-in.
- During teach-in, evaluation is performed using the set mean value.
- If no object is detected in the sensing range, teach-in remains active (LED flashes).
- On successful completion of a teach-in, the potentiometer for adjusting the switching range is disabled.

The teach-in procedure can be repeated as often as required.

Technical specifications

Type	3RX4 000
Required hardware	PC with VGA video card, serial interface COM1 or COM2
Required software	MS-DOS, Version 3.1 Windows 3.X, Windows 95, 98 Windows NT
Operating voltage	AC 100 ... 240 V, DC 24 V

Software update on the Internet: www.siemens.de/bero

Selection and ordering data

Design	DT	Order No.	PS	Approx. weight per PU
				kg
SONPROG interface device	A	3RX4 000	1 unit	0.684

Selection and ordering data

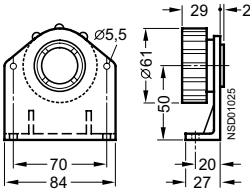
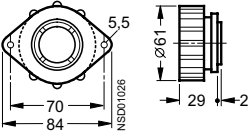
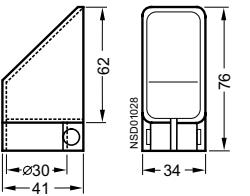
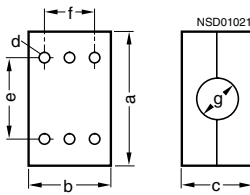
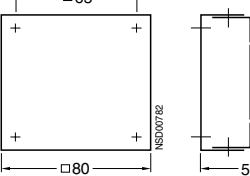
Design	DT	Order No.	PS	Approx. weight per PU kg
	C	3RX1 301	1 unit	0.130
<p>Aligning unit with mounting bracket for M30 Sonar-BERO Swivel range approx. 20° around longitudinal axis of BERO. Following assignment, the BERO is screwed tight in the selected position.</p>				
	C	3RX1 302	1 unit	0.084
<p>Aligning unit with mounting flange for Sonar-BERO M30 Swivel range approx. 20° around longitudinal axis of BERO. Following assignment, the BERO is screwed tight in the selected position.</p>				
	C	3RX1 910	1 unit	0.045
<p>Reflector for M30 Sonar-BERO</p>				
	A	3SX6 283	1 unit	0.027
<p>Mounting clamp (molded plastic) • for Sonar-BERO, M18 form • for Sonar-BERO, M30 form</p>	A	3SX6 284	1 unit	0.040
<p>For dimensions, see Section 7</p> 	A	3SX6 287	1 unit	0.310
<p>Aligning unit for 3SG16 67 Sonar-BERO</p>				

For cable connectors and extension cables, see Section 7.

Sonar-BERO

Notes

3

